

INSTALLATION AND SERVICE MANUAL

PACKAGED ROOFTOP ARRANGEMENTS

FOR HEATING, COOLING AND VENTILATING SYSTEMS

ATTENTION: READ THIS MANUAL, RISM MANUAL, FACTORY INSTALLED OPTIONS MANUAL, UNIT SUBMITTAL DATA SHEETS AND ALL LABELS ATTACHED TO THE UNIT CAREFULLY BEFORE ATTEMPTING TO INSTALL, OPERATE OR SERVICE THESE UNITS! CHECK UNIT DATA PLATES FOR TYPE OF GAS AND ELECTRICAL SPECIFICATIONS AND MAKE CERTAIN THAT THESE AGREE WITH THOSE AT THE POINT OF INSTALLATION. RECORD THE UNIT MODEL NUMBER AND SERIAL NO.(S) IN THE SPACE PROVIDED. RETAIN THIS DOCUMENT FOR FUTURE REFERENCE.

Model No. _____

Serial No. _____

FOR YOUR SAFETY
The use or storage of gasoline or other flammable vapors or liquids in open containers in the vicinity of this appliance is hazardous.

FOR YOUR SAFETY
If you smell gas:
1. Don't touch electrical switches.
2. Extinguish any open flames.
3. Immediately call your gas supplier.

▲ WARNING Improper installation, adjustment, alteration, service or maintenance can cause property damage, injury or death. This appliance must be installed by a licensed contractor or qualified service personnel. Read these installation, operating and maintenance instructions thoroughly before installing or servicing this equipment.

▲ WARNING Install, operate and maintain unit in accordance with manufacturer's instructions to avoid exposure to fuel substances or substances from incomplete combustion which can cause death or serious illness. The state of California has determined that these substances may cause cancer, birth defects, or other reproductive harm. Install and Service this product to avoid exposure to airborne particles of glasswool fibers and/or ceramic fibers known to the State of California to cause cancer through inhalation.



INSTALLER'S RESPONSIBILITY
Installer Please Note: This equipment has been test fired and inspected. It has been shipped free from defects from our factory. However, during shipment and installation, problems such as loose wires, leaks or loose fasteners may occur. **It is the installer's responsibility to inspect and correct any problems that may be found.**

RECEIVING INSTRUCTIONS
Inspect shipment immediately when received to determine if any damage has occurred to the unit during shipment. After the unit has been uncrated, check for any visible damage to the unit. If any damage is found, the consignee should sign the bill of lading indicating such damage and immediately file claim for damage with the transportation company.

IMPORTANT: Look in direction of unit air flow to determine whether unit is right hand or left hand accessible.

 **MESTEK, INC.**
260 NORTH ELM ST., WESTFIELD, MA 01085
TEL: (413) 564-5540 FAX: (413) 562-5311
www.mestek.com



TABLE OF CONTENTS

I. RECEIVING	
Pre-Installation Instructions	2
II. GENERAL REQUIREMENTS	3-5
Rigging	4
Combustion Air Considerations	4
Location	5
Mounting/Locations	5
III. INSTALLATION	
Installation Clearances	6
Mounting on Field Furnished Supports.....	6
Mounting on Roof Curb	6, 7, 8, 9
Access Panel Removal.....	6
Venting.....	10
Duct Connections	10
Gas Piping.....	10-11
Modulating Gas Control.....	11
Electrical Connections.....	11-13
DX Coil Equipped Units.....	13
Chilled Water Coil Equipped Units	13
Evaporative Cooling Equipped Units.....	13
IV. OPERATION	
General Information.....	14
Gas Control System	14
Optional Gas Controls	14-15
Air Handling Requirements and Adjustments	15-16
Lighting.....	16
Gas Input Adjustment.....	16-17
Pilot Adjustment.....	17
Primary Air Shutter Adjustment.....	17
Controls	17
V. START UP	17-18
VI. MAINTENANCE	18-20
VII. TROUBLESHOOTING	21-26
VIII. REPLACEMENT PARTS	26
IX. SERVICE NOTE	26
X. WARRANTY	26
XI. UNIT/SHIP WEIGHTS	27-29
XII. CENTER OF GRAVITY	30-33
XIII. UNIT NUMBER DESCRIPTION	34
XIV. START UP SHEET	36

Unless otherwise specified, the following conversions may be used for calculating SI unit measurements:

1 foot = 0.305 m	1 inch water column = 0.249 kPa
1 inch = 25.4 mm	1000 Btu per hour = 0.293 kW
1 psig = 6.894 kPa	1000 Btu/Cu. Ft. = 37.5 MJ/m ³
1 pound = 0.435 kg	liter/second = CFM x 0.472
1 gallon = 3.785 L	meter/second = FPM ÷ 196.8
1 cubic foot = 0.028 m ³	

The following terms are used throughout this manual to bring attention to the presence of potential hazards or to important information concerning the product:

▲ DANGER Indicates an imminently hazardous situation which, if not avoided, will result in death, serious injury or substantial property damage.

▲ WARNING Indicates an imminently hazardous situation which, if not avoided, could result in death, serious injury or substantial property damage.

▲ CAUTION Indicates an imminently hazardous situation which, if not avoided, may result in minor injury or property damage.

NOTICE: Used to notify of special instructions on installation, operation or maintenance which are important to equipment but not related to personal injury hazards.

I. RECEIVING INSTRUCTIONS

Inspect shipment immediately when received to determine if any damage has occurred to the crate during shipment.

After the unit has been uncrated, check for any visible damage to the unit. Check motor position and turn blower wheel to determine if damage has occurred to these critical parts.

If any damage is found, the cosignee should sign the bill of lading indicating such damage and immediately file claim for damage with transportation company.

PRE-INSTALLATION INSTRUCTIONS

When the unit is received and uncrated, check the external data plate and all labels on the unit for type of gas, electrical, and operational specifications to confirm that these agree with those at point of installation. If the unit is equipped with an Outdoor Duct Furnace, also check the data plate and all labels located inside each furnace.

Every rooftop unit will include an informational packet which will include the following: The blower manual, outdoor duct furnace and evaporative cooler/cooling coil manuals (if applicable to the unit order), wiring diagram(s), factory installed-service convenience options manual (if applicable to unit order) and special controls/data sheets.

NOTICE: It is the owner's responsibility to provide any scaffolding or other apparatus required to perform emergency service or annual/periodic maintenance to this equipment.

II. GENERAL SAFETY REQUIREMENTS

▲ WARNING Open all disconnect switches before installing the unit. Failure to do so may result in personal injury or death from electrical shock.

▲ WARNING Failure to comply with the general requirements may result in extensive property damage, severe personal injury or death.

▲ WARNING This product must be installed by a licensed plumber or gas fitter when installed within the Commonwealth of Massachusetts.

▲ WARNING Do not alter the duct furnace in any way or damage to the unit, severe personal injury or death will occur.

▲ WARNING Never service any component without first disconnecting all electrical and gas supplies to the unit or severe personal injury or death may occur.

▲ CAUTION Insure that all power sources conform to the unit requirements or damage to the unit may result.

For all units that are equipped with gas fired outdoor duct furnaces (certified by ETL) installation must be made in accordance with local codes, or in the absence of local codes, with the latest edition of ANSI Standard Z223.1 (N.F.P.A. No. 54) National Fuel Gas Code. All of the ANSI and NFPA Standards referred to in these installation instructions are those that were applicable at the time the design was certified. The ANSI Standards are available from the American National Standards Institute, Inc., 11 West 42nd Street, New York, NY, 10036 or www.ansi.org. The NFPA Standards are available from the National Fire Protection Association, Batterymarch Park, Quincy, MA 02269.

If installed in Canada, the installation must conform with local building codes, or in the absence of local building codes, with CSA B149.1 "Installation Codes for Natural Gas Burning Appliances and Equipment" or CSA B149.2 "Installation Codes for Propane Gas Burning Appliances and Equipment". These outdoor duct furnaces have been designed for and certified to comply with CSA 2.8.

These units have been designed **certified for outdoor use only**, and may be located on the roof of the building or at any convenient location external to the building to be heated.

Make certain that the power sources conform to the requirements of the heater.

Follow installation instructions CAREFULLY to avoid creating unsafe conditions. All wiring should be done and checked by a qualified electrician, using copper wire only. All gas connections should be made and leak-tested by a suitably qualified individual, per instructions in this manual.

Use only the fuel for which the heater is designed (see nameplate). Using LP gas in a heater that requires natural gas, or vice versa, will create the risk of gas leaks, carbon monoxide poisoning and explosion.

▲ WARNING Do not attempt to convert the heater for use with a fuel other than the one intended. Such conversion is dangerous, as it could create unsafe conditions that result in death, serious injury or substantial property damage.

Make certain that power source conforms to electrical requirements of heater. Disconnect power before installing or servicing heater. If power disconnect is out of sight, lock it in open position and tag it to prevent unexpected application of power. Failure to do so could result in fatal electric shock.

▲ WARNING Do not depend upon a thermostat or other switch as the sole means of disconnecting power when installing or servicing heater. Always disconnect power at main circuit breaker as described above. Failure to do so could result in fatal electric shock.

Special attention must be given to any grounding information pertaining to this heater. To prevent the risk of electrocution the heater must be securely and adequately grounded. This should be accomplished by connecting a grounded conductor from the service panel to the conduit box of the heater. To ensure proper ground, the grounding means must be tested by qualified field technician.

Do not insert fingers or foreign objects into the heater or its air moving device. Do not block or tamper with the heater in any manner while in operation or just after it has been turned off, as some parts may be hot enough to cause injury.

This heater is intended for general heating applications ONLY. It must NOT be used in potentially dangerous locations such as flammable explosive, chemical-laden or wet atmospheres.

In cases in which property damage may result from malfunction of the heater, a backup system or a temperature sensitive alarm should be used.

The venting is an integral part of the unit and **must not be altered in the field**. The Natural Vented units are equipped with a ventcap which is designed for natural draft venting. Air for combustion enters the base of the vent cap through a protective grill and products of combustion are discharged at the upper section of the vent cap. This vent cap is shipped in a separate carton and should be installed per the Venting section of the Outdoor Rooftop Gas-Fired Duct Furnace Installation and Service Manual. The Power Vented unit has a induced draft venting system. The combustion air inlet and products of combustion discharge grills are located in the upper section of the Duct Furnace side access panel.

A pilot burner plate is provided in the Duct Furnace for access to the pilot burner and ignition system without removing the burner drawer. Clearance between the external unit and any obstruction must be sufficient for proper servicing of pull out burner drawer. See Figure 2 & 3 for this clearance.

These units are certified for operation on either natural or propane gases. If a unit is to be installed at an altitude exceeding 2000 feet (610 m) above sea level, derate the unit input of each duct furnace by 4% for each 1000 feet (305 m) above sea level. Special main burner gas orifices are required for installations above 2000 feet (610 m).

In Canada, if unit is to be installed at altitudes of 2000 feet (610 m) to 4500 feet (1372 m), each duct furnace must have the main burners re-orificed to give 90% of the normal altitude input rating.

If the unit was ordered from the factory for high altitude operation, confirm input rating. See Gas Input Adjustment.

RIGGING

Rig unit using either belt or cable slings. Use spreader bars to protect the top of the unit when it is lifted. See Figure 1.

On units with a total length of less than 104 inch (2642 mm), excluding evaporative cooler, two holes are provided in the base rail on each side of the unit. Slide pipes beneath the unit through these holes and attach rigging to pipes for lifting the unit.

On units with a total length of a 104 inch (2642 mm) or greater, excluding evaporative cooler, lifting lugs attached to the base rail are provided. Attach rigging to lugs for lifting the unit. For distance between lifting lugs and total unit lengths, refer to original Submittal Sheets supplied specified for the unit. Also see Center of Gravity and Weights Sections in this manual.

Figure 1

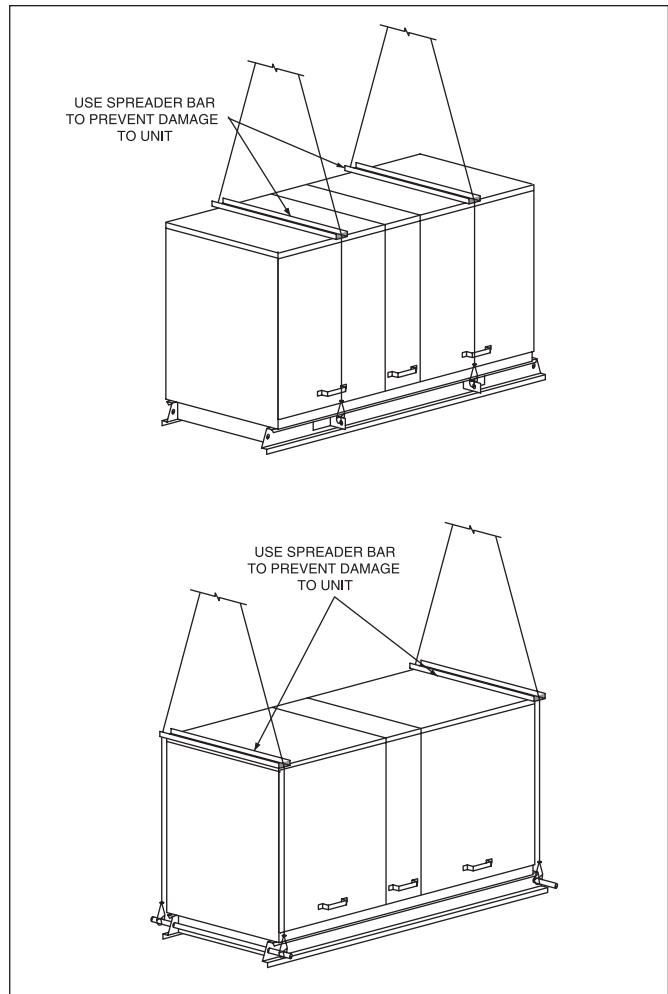

COMBUSTION AIR CONSIDERATIONS

The presence of chlorine vapors or other corrosive vapors in the combustion air supply for gas-fired heating equipment presents a potential corrosive hazard. Chlorine will, when exposed to flame, precipitate from the compound (usually freon or degreaser vapors) and go into solution with any condensation that is present in the heat exchanger or associated parts. The result is hydrochloric acid which will readily attack all metals, including 300 grade stainless steel. Care should be taken to separate these vapors from the combustion process. This may be done by wise location of the unit with regard to exhausters or prevailing wind direction.

LOCATION

Before placing rooftop unit in its permanent location, make certain that the roof is capable of carrying the additional load of this equipment. Check the unit weight given at the end of this manual.

Refer to Figure 2 & 3 for required clearances to combustible material.

⚠ WARNING Do not place unit in a location where service personnel can not safely service this equipment (i.e. roof edge, skylights, etc.) or personal injury could result.

NOTICE: If your unit is equipped with (N2) through the base utilities and/or (N3) service convenience package - refer to Submittal GAN2, review in entirety before mounting the unit.

MOUNTING/LOCATIONS

These units are suitable for installation on combustible flooring.

Single, double and triple duct furnace only models have base rails which can be mounted either on solid planking or steel channels. All other units installed on field furnished supports must use the recommended method shown in Mounting on Field Furnished Supports or equivalent.

Roof curb kits for rooftop units are shipped unassembled. Included with the roof curb kit are insulated or uninsulated curb rails, bolts and screws needed for assembly, sealant, a roll of self-adhering rubber gasketing, and installation instructions. Roof insulation, cant stripping, flashing, roof felts, caulking, and nails must be furnished by the installer. See separate roof curb specifications. See Figures 5, 6, 7 & 8 for roof curb information.

**Figure 2
Minimum
Clearances to
Combustible
Material or
Obstructions**

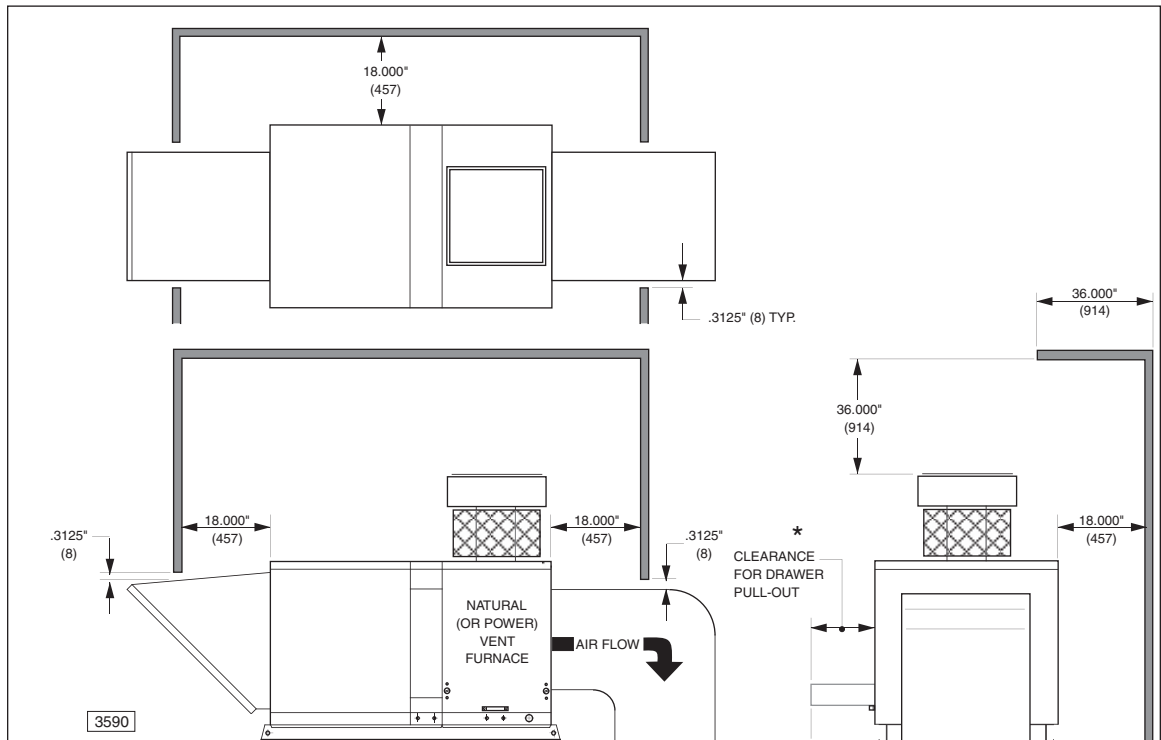
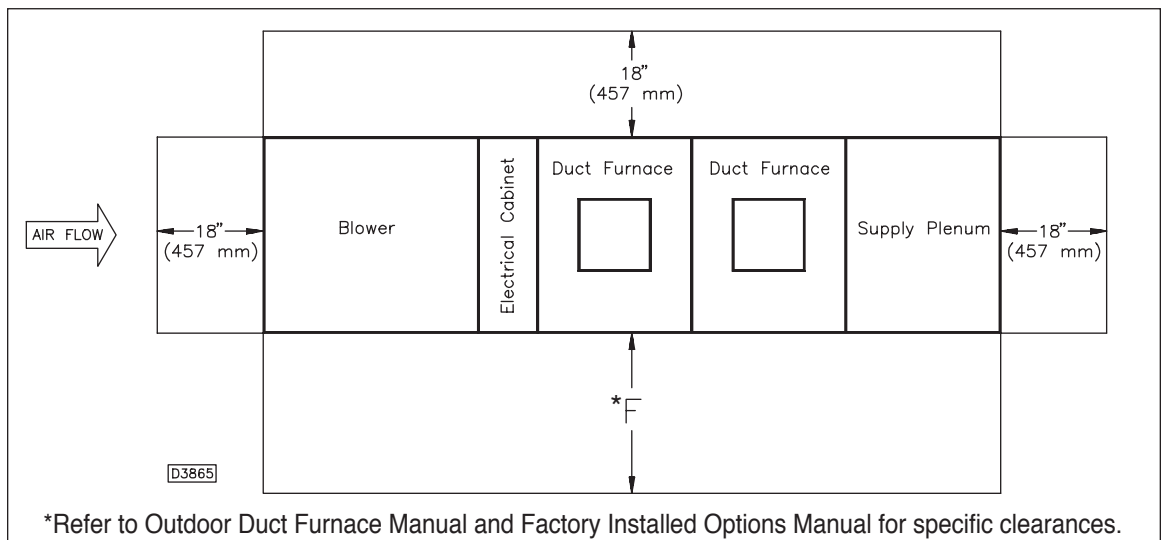

Figure 3

* Note: The unit is equipped with hinged access doors: allow 36 inches minimum for clearance (on access side) to fully open door and lock in an open position.



*Refer to Outdoor Duct Furnace Manual and Factory Installed Options Manual for specific clearances.

III. INSTALLATION

▲ WARNING Open all disconnect switches and secure in that position before installing unit. Failure to do so may result in personal injury or death from electrical shock.

Installation must conform with local building codes or in the absence of local codes with the latest edition of the National Fuel Gas Code ANSI Z223.1 (N.F.P.A. No. 54) National Fuel Gas Code.

A heat loss study and a complete layout of the system should be made first.

When locating the unit in its permanent location, make certain that the roof is capable of carrying the additional load of the equipment. **Check the unit net weights section of this manual.**

Make certain that clearances are provided for service, minimum clearance to combustible material and to venting cap. See Figure 2 for this information.

Ducts connected to units which do not have either a blower section or a supply plenum must have a removable access panel in the duct, which is connected to a duct furnace. The duct openings shall be accessible when the unit is installed in service and shall be of such size that smoke or reflected light may be observed inside the casing to indicate the presence of leaks in the heating element. The covers for the panels shall be attached in such manner as to prevent leaks. Ducts exposed to the outdoors must be insulated and sealed to prevent water from entering either the unit or building through the duct.

If a single, double or triple duct furnace only unit is connected to a return air duct or any other inlet air restriction, the appliance shall be installed on the positive pressure side of the air circulating blower.

▲ CAUTION Remove wooden shipping support from beneath blower housing of Blower Section to prevent possible unit damage or improper unit operation (if applicable).

ACCESS PANEL REMOVAL

The air handler section(s) of this unit are equipped with hinged access doors. The hinged doors include dual, quick opening tool-less latches and full perimeter gasketing to assure a water resistant seal. Door stops are included to guard against closure while open.

Other sections are equipped with access panels that are held in place with two “grip” latches. To remove these access panels: use a slotted head screw driver to turn the latch screwhead counterclockwise. Using the handle provided, push the panel upwards. Pull the bottom of the panel out and lower the panel to disengage it from the top lip.

To replace access door panels: guide the panel door upwards on the tracks, and push up into the top lip, swing and lower the panel in place until it engages with the bottom panel. Turn the screwhead on each latch clockwise. The screw must turn freely one quarter turn before resistance is felt in order for the lock to engage. If latch does not hold, turn screw counter-clockwise several turns and repeat the above procedure.

INSTALLATION CLEARANCES

Minimum clearances to combustible material are shown on the unit data plate. It is important that clearances be maintained for servicing the unit (refer to Submittal Insert for service clearances), and that minimum clearances are provided from the unit (including vent cap, if Natural Vent model) to combustible material. Clearances around the outside air hood (if unit is so equipped) must be unobstructed. See Figure 2.

MOUNTING ON FIELD FURNISHED SUPPORTS

Single, double, triple duct furnace only models have base rails which are suitable for mounting either directly on solid planking or steel channels. Never install the unit on a soft roof where the rails could sink, reducing clearance between the bottom panel and the roof, or cause damage to the roofing surface.

All other models must use the following method or an equivalent when unit supports are field furnished: Each section of the Rooftop unit must be supported, which includes supports located at both ends. If the unit consists of a High CFM Blower section, a DX Coil, a Duct Furnace and a Supply Plenum, five supports are required. See Figure 4.

Figure 4

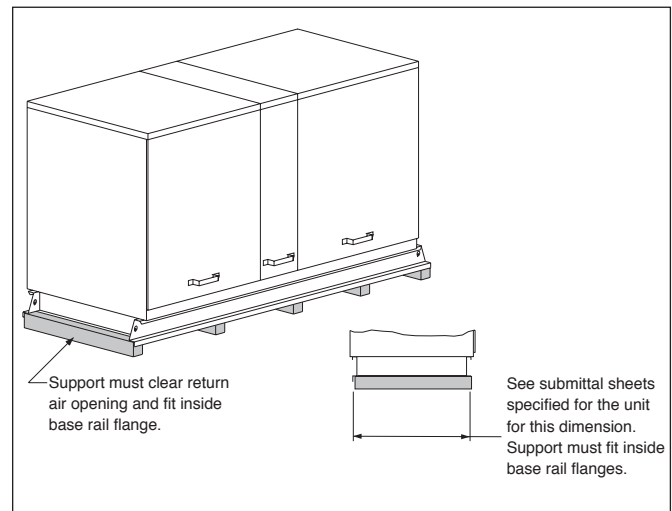

MOUNTING ON ROOF CURB

Assemble and install roof curb per Roof Curb Installation Instructions. See Figures 5, 6, 7 & 8 for roof opening sizes, distance between openings and unit relationship to roof curb.

Figure 5 - Roof Curb Kits Dimensional Data

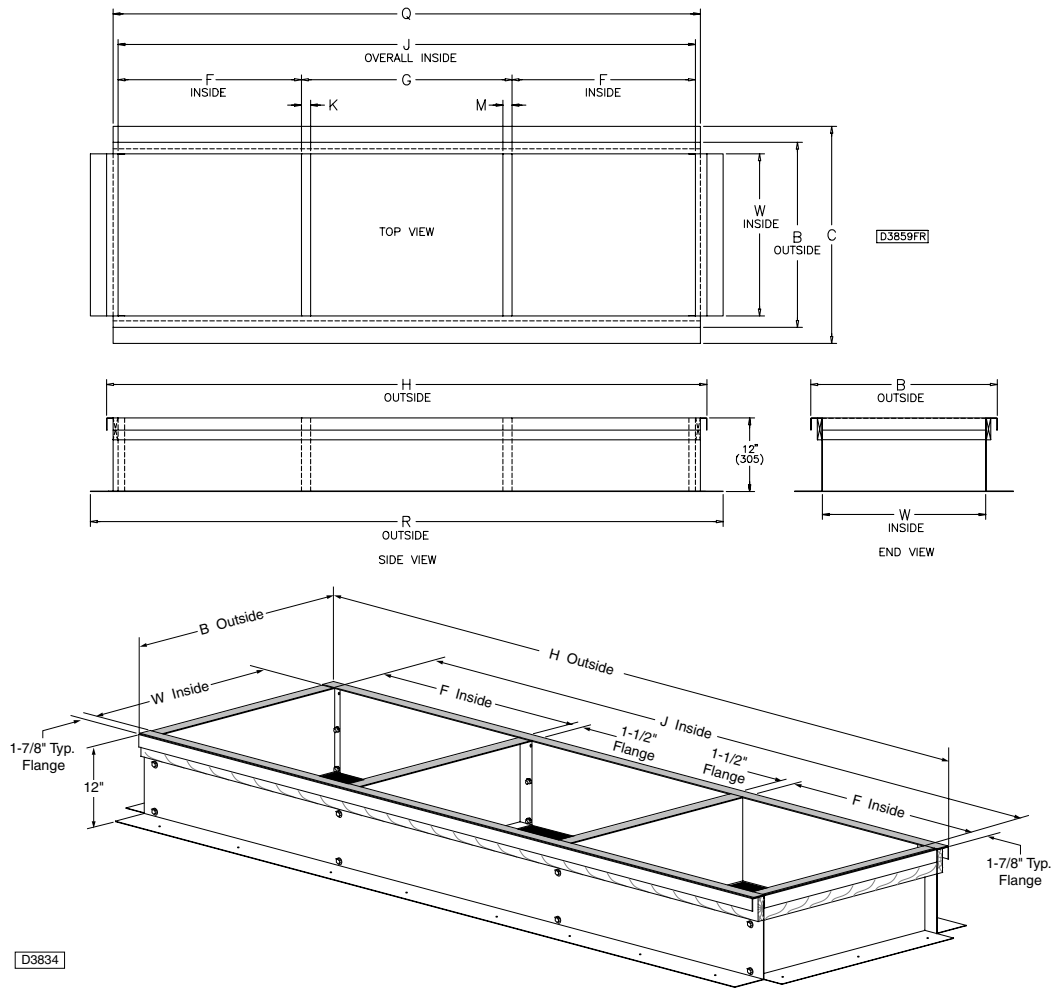

D3834

CURB KIT NO.	ROOFTOP ARRANGEMENT (RA)	CAPACITY (CA)	F	G	H	J	Q	R	K	M
RC001- *	B & D	10/40	29-5/8 (752)	8-1/8 (206)	71-1/8 (1,806)	67-3/8 (1,711)	69" (1,753)	76-3/8 (1,940)	1-1/2 (38)	1-1/2 (38)
RC002- *										
RC003- *	B & D	50/80	34-1/8 (867)	97-1/8 (2,467)	93-3/8 (2,371)	95" (2,413)	102-3/8 (2,600)			
RC004- *				C & E	10/40					
RC005- *	G	50/80	37-1/8 (943)	55-1/4 (1,403)	133-1/4 (3,385)	129-1/2 (3,289)	131-1/8 (3,331)	138-1/2 (3,518)		
	J	20/40								
	K	10/40								
RC006- *	G	20/40	37-3/16 (944)	29-3/16 (741)	107-5/16 (2,726)	103-9/16 (2,631)	105-3/16 (2,672)	112-9/16 (2,859)		
RC007- *	C & E	50/80	30-1/8 (765)	59" (1,499)	123" (3,124)	119-1/4 (3,029)	120-7/8 (3,070)	128-1/4 (3,257)		
RC008- *										
RC009- *	G	12	37-5/16 (948)	80-15/16 (2,056)	159-5/16 (4,046)	155-9/16 (3,951)	157-1/4 (3,994)	164-1/2 (4,178)		
	J & K	50/80								
	L	10/40								
RC010- *	J	12	36-15/16 (936)	107-11/16 (2,735)	185-5/16 (4,707)	181-9/16 (4,612)	183-1/4 (4,655)	190-1/2 (4,839)		
	L	50/80								

CAPACITY (CA)	CURB KIT NO.	ROOFTOP ARRANGEMENT (RA)	F	G	H	J	Q	R	K	M
20 OR 40	RC011- *	M & P	N/A	N/A	45-1/4 (1,149)	41-1/2 (1,054)	43-1/8 (1,095)	50-1/2 (1,283)	N/A	N/A
	RC012- *	N & R	29-5/8 (752)	8-1/8 (206)	71-1/8 (1,806)	67-3/8 (1,711)	69" (1,753)	76-3/8 (1,940)	1-1/2 (38)	1-1/2 (38)
	RC001- *	S	38-1/8 (968)	N/A	81-7/16 (2,069)	77-11/16 (1,973)	79-5/16 (2,015)	86-11/16 (2,202)	1-1/2 (38)	N/A
	RC002- *									
	RC006- *	T & U	37-3/16 (944)	29-3/16 (741)	107-5/16 (2,726)	103-9/16 (2,630)	105-3/16 (2,672)	112-9/16 (2,859)	1-1/2 (38)	1-1/2 (38)
	RC005- *	W	37-1/8 (943)	55-1/4 (1,403)	133-1/4 (3,385)	129-1/2 (3,289)	131-1/8 (3,331)	138-1/2 (3,518)		

ROOFTOP ARRANGEMENT (RA)	CURB KIT NO.	CAPACITY (CA)	W	B	C
ALL	* -1	10/15	26-7/16 (671)	30-3/16 (767)	35-7/16 (900)
	* -2	20/25/50	37-7/16 (951)	41-3/16 (1,046)	46-7/16 (1,179)
	* -3	30/35/60/70	48-7/16 (1,230)	52-3/16 (1,325)	57-7/16 (1,459)
	* -4	40/80/12	53-15/16 (1,370)	57-11/16 (1,465)	62-15/16 (1,599)

*Curb Kit Suffix Legend	
Capacity	Suffix
10, 15	-1
20, 25, 50	-2
30, 35, 60, 70	-3
40, 80, 12	-4

Figure 6

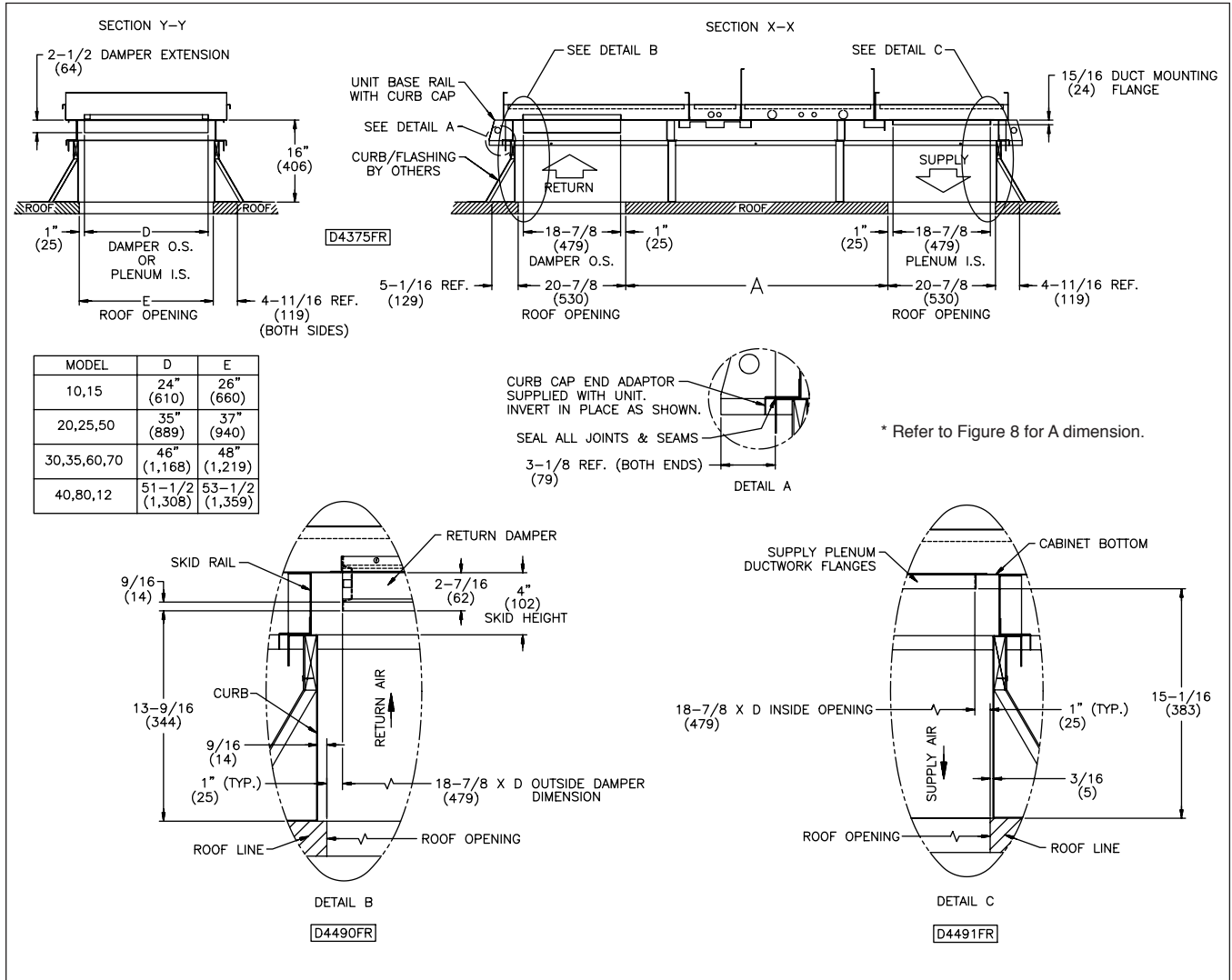

Figure 7 - Unit/Curb End Rail Assembly

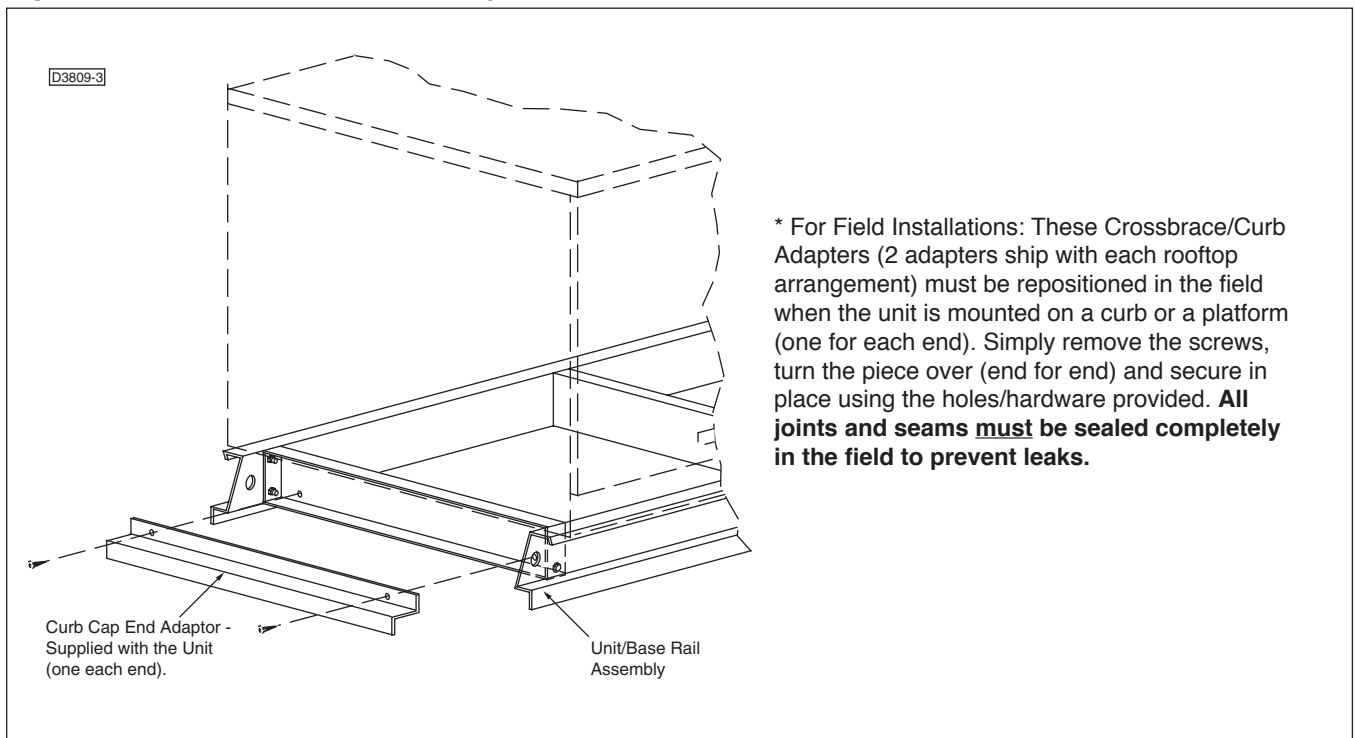
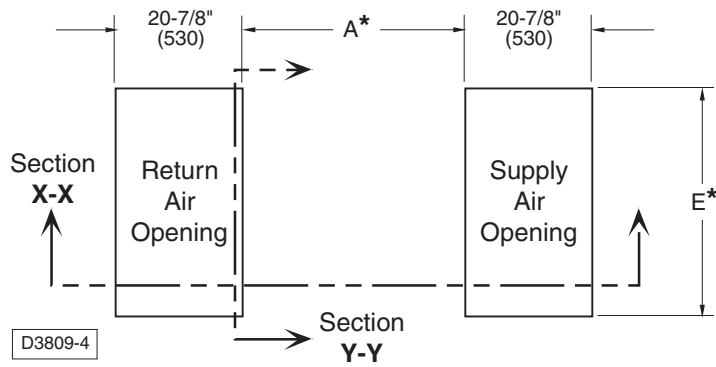

Figure 8 - Roof Curb Specifications



Unit Type [UT] "RT, PV or AH"	
Capacity [CA]	Dimension E *
10/15	26" (660)
20/25/50	37" (940)
30/35/60/70	48" (1219)
40/80/12	53-1/2" (1359)

* All Dimensions Shown Have Been Calculated To Include A One (1) Inch Clearance Around Return And Supply Ducts.

Unit Type [UT] "RT or PV"							
** Rooftop Arrangement [RA]	FURNACE	Capacity [CA]	Unit Specifications (References)				* Dimension A
			Blower		Coil	Supply Plenum	
			St'd.	High CFM			
C, E	SINGLE	10 - 40	✓			✓	50-7/8" (1292)
J		20 - 40		✓		✓	87-1/16" (2211)
L		10 - 40		✓	✓	✓	113" (2871)
C, E	DUAL	50 - 80	✓			✓	76-7/8" (1952)
J		50 - 80		✓		✓	113" (2871)
L		50 - 80		✓	✓	✓	139" (3531)
J		12		✓		✓	139" (3531)

Unit Type [UT] "AH"						
** [RA]	[CA]	Blower		Coil	Supply	* A
		St'd.	Hi			
N, R	20 or 40	✓			✓	24-7/8" (631)
T	20 or 40		✓		✓	61-1/16" (1551)
W	20 or 40	✓	✓	✓	✓	87-1/16" (2211)

** Rooftop Arrangements [RA] B, D, G, K, M, P, S & U Are Without a Return Air Dimensions For These Units Rooftop Openings. Refer To Unit Submittals For More Detail.

D3809-1

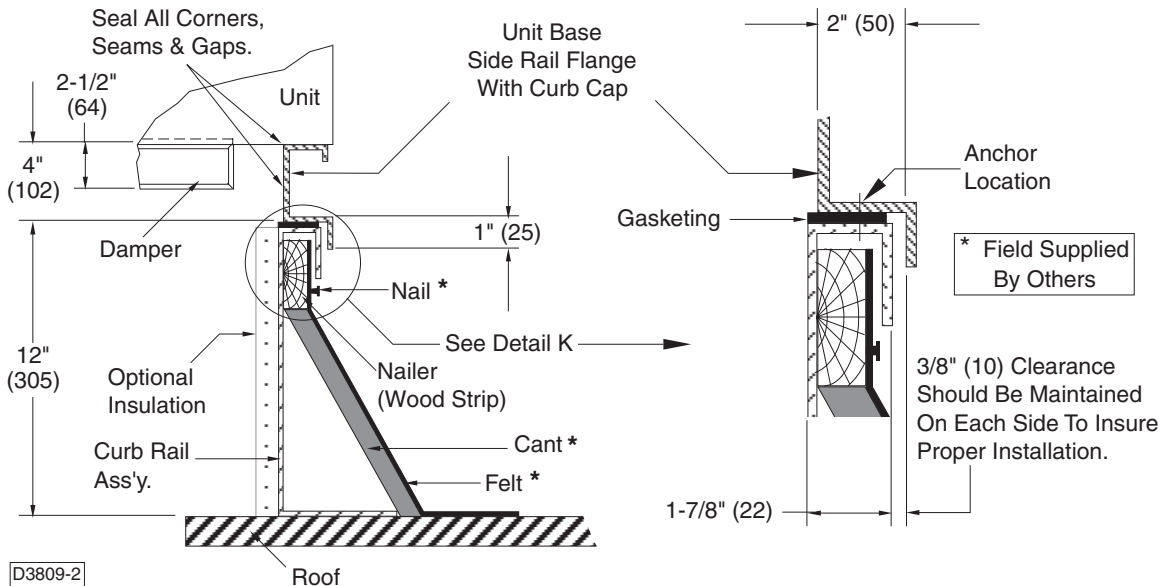

D3809-2

Section Curb Side Rail

Detail K

VENTING†

All venting installations shall be in accordance with the latest edition of Part 7, "Venting of Equipment", of the National Fuel Gas Code, ANSI Z223.1 or applicable provisions of local building codes.

▲ WARNING The venting is an integral part of the unit and must not be altered in the field.

The Natural Vented units are equipped with a vent cap which is designed for natural draft venting. Air for combustion enters the base of the vent cap through a protective grill and products of combustion are discharged at the upper section of the vent cap. † **This vent cap is shipped in a separate carton and should be installed per the Venting section of the Outdoor Rooftop Gas-Fired Duct Furnace Installation and Service Manual.**

The Power Vented unit has a induced draft venting system. The combustion air inlet and products of combustion discharge louvers are located in the upper section of the Duct Furnace side access panel. **Never locate these units in an area where the flue products discharge outlet may be directed at any fresh air vents. See the Outdoor Rooftop Gas-Fired Duct Furnace Installation and Service Manual for installation and servicing requirements.**

DUCT CONNECTIONS

All ductwork must be properly supported so that no strain is put on the unit. Do not alter or bend the discharge duct flanges supplied on your furnace/air handler.

Ducts connected to units which do not have either a blower section or a supply plenum must have a removable access panel in the duct which is connected to a duct furnace. The duct openings shall be accessible when the unit is installed in service, and shall be of such size that smoke or reflected light may be observed inside the casing to indicate the presence of leaks in the heating element. The covers for the panels shall be attached in such a manner as to prevent leaks. Ducts exposed to the outdoors must be insulated and sealed to prevent water from entering either the unit or building through the duct.

If a single, double or triple duct furnace only unit is connected to a return air duct, or any other inlet air restriction, the appliance shall be installed on the positive pressure side of the air circulating blower.

When connecting return air duct to Standard or High CFM cabinets, attach duct to return air opening flange when no dampers are used. Otherwise, if dampers are used, attach return air duct around collar at bottom of damper assembly. Also refer to the Submittal Data Sheets specified for your unit.

When connecting supply air duct to Supply Plenum, attach duct to supply air opening flange when no dampers are used. Otherwise, if dampers are used, attach supply air duct around collar at bottom of damper assembly.

GAS PIPING††

All gas piping must be installed in accordance with local codes. It is required that a ground union be installed adjacent to the gas valve of each duct furnace, and a ground union be installed just external of each duct furnace for unit servicing. On vertical runs, a drip leg should be provided upstream of any control manifold. A gas shutoff valve should be, or may be required by local codes, installed upstream of the external ground union for each duct furnace. A 1/8 inch N.P.T. plugged tapping, accessible for test gauge connection, must be installed immediately upstream of the unit gas supply connection.

†† **For complete Gas Piping installation, see Outdoor Rooftop Gas-Fired Duct Furnace Installation and Service Manual, and if applicable the Factory Installed Options Manual.**

It is recommended that the gas piping not be installed through the bottom of the duct furnace bottom panel. If piping must penetrate the duct furnace bottom panel, it must be sealed to prevent water leakage.

Gas piping must be installed to allow for removal of burner drawer for unit maintenance.

▲ WARNING To avoid equipment damage or possible personal injury, do not connect gas piping to this unit until a supply line pressure/leak test has been completed. Connecting the unit before completing the pressure/leak test may damage the unit gas valve and result in a fire hazard.

▲ CAUTION Do not rely on a gas shutoff valve to isolate the unit while conducting gas pressure/leak tests. These valves may not be completely shutoff, exposing the unit gas valve to excessive pressure, resulting in damage.

▲ CAUTION Do not over-tighten the inlet gas piping at unit gas valve or stresses that could crack the valve may result.

▲ WARNING Never use an open flame to detect gas leaks. Explosive conditions may exist which would result in personal injury or death.

The gas line should be supported so that no strain is placed on the unit. Pipe compounds which are not soluble to liquid petroleum gases must be used on threaded joints.

The appliance and its individual shutoff valve must be disconnected from the gas supply piping system during any pressure testing of that system at test pressures in excess of 1/2 psi (3.5 kPa).

The appliance must be isolated from the gas supply piping system by closing the individual manual shutoff valve during any pressure testing of the gas supply piping system at test pressures equal to or less than 1/2 psi (3.5 kPa).

For additional gas piping information, including pipe sizing and drip leg installation, refer to Outdoor Rooftop Gas-Fired Duct Furnace Installation and Service Manual.

For additional piping information, refer to the National Fuel Gas Code Z233.1 (latest edition).

NOTICE: If the gas duct furnace is to be fired with LP gas, consult local LP gas dealer for piping size information.

NOTICE: UNIT INSTALLATION FOR USE WITH PROPANE (BOTTLED) GAS MUST BE MADE BY A QUALIFIED LP GAS DEALER OR INSTALLER. HE WILL INSURE PROPER JOINT COMPOUNDS ARE USED FOR MAKING PIPE CONNECTIONS; THAT AIR IS PURGED FROM LINES; THAT A THOROUGH TEST IS MADE FOR LEAKS BEFORE OPERATING THE UNIT; AND THAT IT IS PROPERLY CONNECTED TO PROPANE GAS SUPPLY SYSTEM.

Before any connection is made to an existing line supplying other gas appliances, contact the local gas company to make certain that the existing line is of adequate size to handle the combined load.

Check all connections for leaks with soap solution.

▲ WARNING Never use an open flame to detect gas leaks. Explosive conditions may exist which would result in personal injury or death.

MODULATING GAS CONTROL (OPTIONAL)*

*Also refer to *Outdoor Duct Furnace Installation Manual* supplied with your unit.

Electronic: On units equipped with electronic modulating control, follow control manufacturer's installation instructions for sensing of outlet air temperature.

ELECTRICAL CONNECTIONS

	<p>▲ WARNING</p> <p>HAZARDOUS VOLTAGE! DISCONNECT ALL ELECTRIC POWER INCLUDING REMOTE DISCONNECTS BEFORE SERVICING. Failure to disconnect power before servicing can cause severe personal injury or death.</p>
--	--

All electrical connections must conform to the latest edition of ANSI/NFPA No. 70 National Electrical Code and applicable local codes. In Canada, to the Canadian Electrical Code, Part I CSA Standard C22.1.

The rooftop packaged unit is wired at the factory and ready to be connected. Actual unit wiring will differ according to the options chosen. Each unit is shipped with its own wiring diagram; refer to this wiring diagram for all electrical connections to the unit.

All electrical connections, line voltage and thermostat, are made in the Electrical Cabinet (See Figure 9). Line voltage connections are made at the High Voltage Terminal Block. Thermostat connections are made at the Main Connection Board (See Figure 10).

▲ CAUTION Do not use any tools (i.e. screwdriver, pliers, etc.) across terminals to check for power. Use of a voltmeter is recommended.

Figure 9 - Standard Blower Cabinet, Single Duct Furnace with Supply Plenum & Various Options Shown

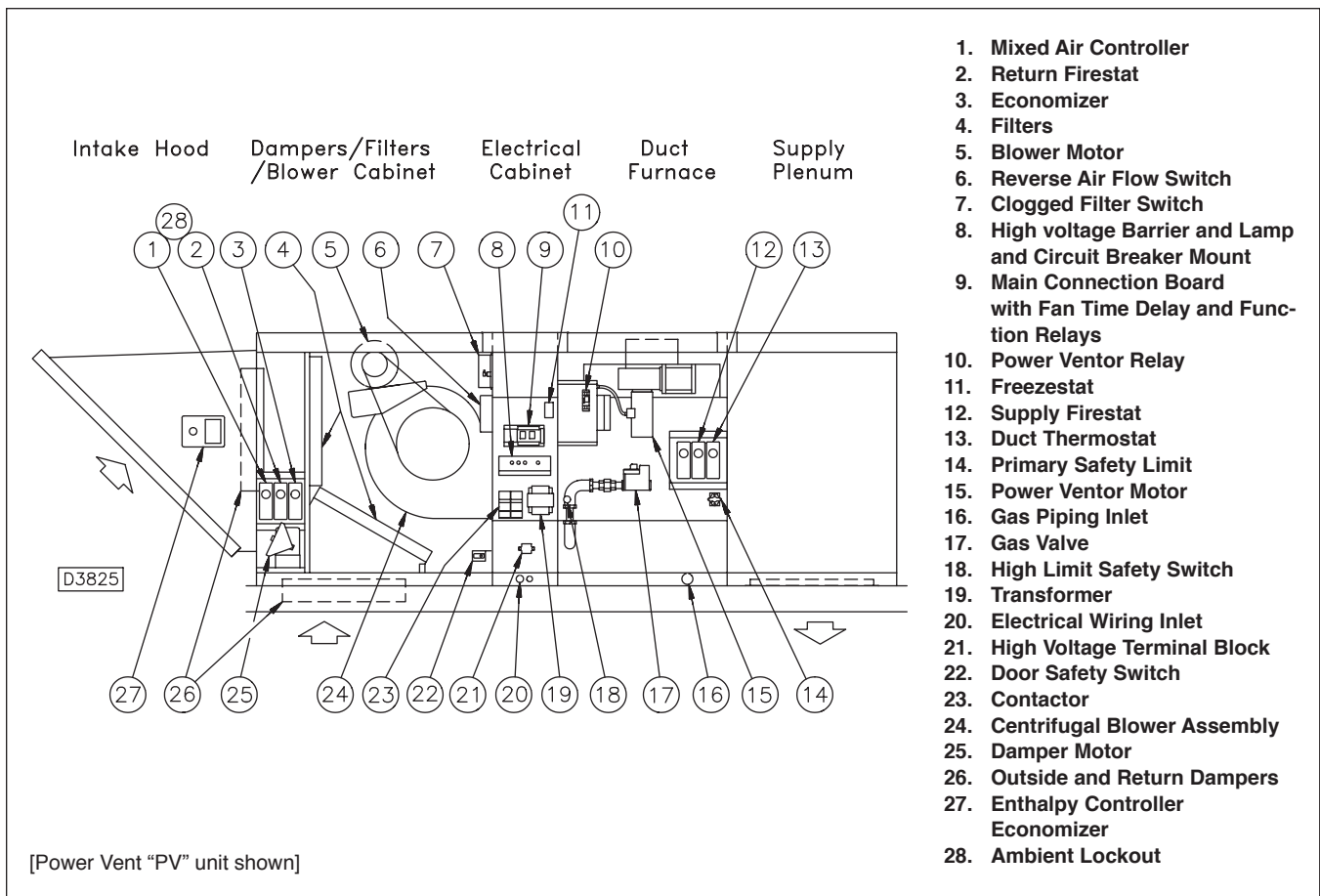
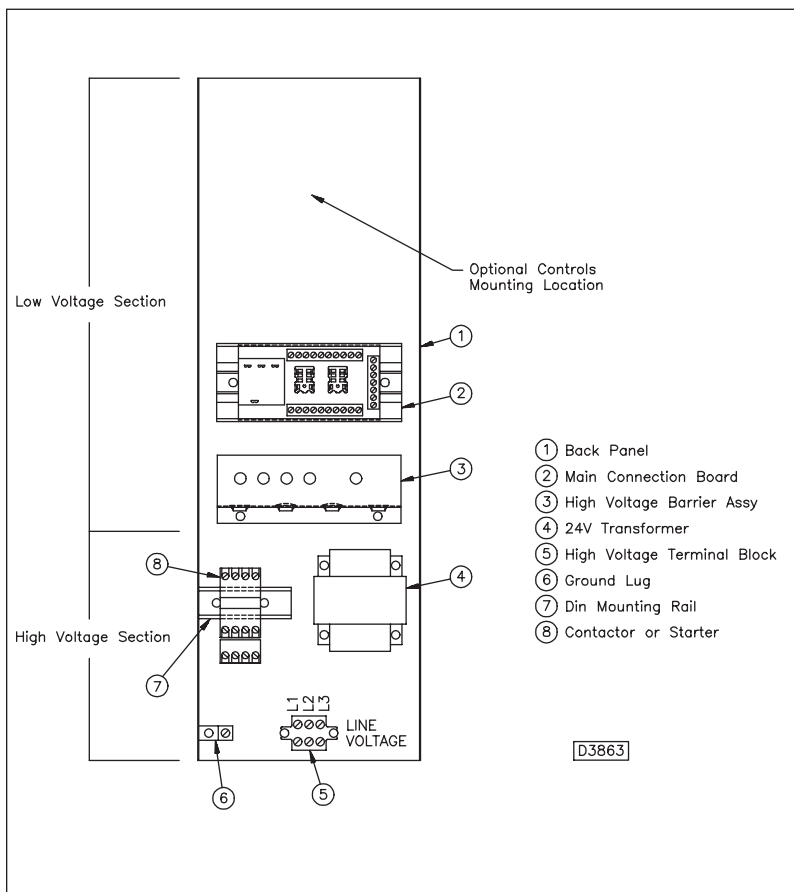

Figure 10 - Electrical Cabinet



Outdoor line voltage conduits leading into the unit should be installed to prevent rain from wetting any high voltage wire. Locate the thermostat in accordance with the instructions supplied with the thermostat. All field wiring must have a minimum temperature rating of 185°F (85°C). Control wiring must be a minimum of 18 gauge wire size. Control wiring must be sized for the length of run.

Locate line voltage disconnect box per local codes. If mounting the disconnect box to the unit, never mount it to an unit access panel. Possible locations include the front of the blower or filter section, the outdoor air hood or the rear of the supply plenum (See Figure 11). Electrical conduit must be routed so as not to interfere with removal of any access panel.

NOTICE: Should any original wire supplied with the unit have to be replaced, it must be replaced with wiring having a temperature rating of at least 221°F (105°C).

Figure 11 - Disconnect Box Locations

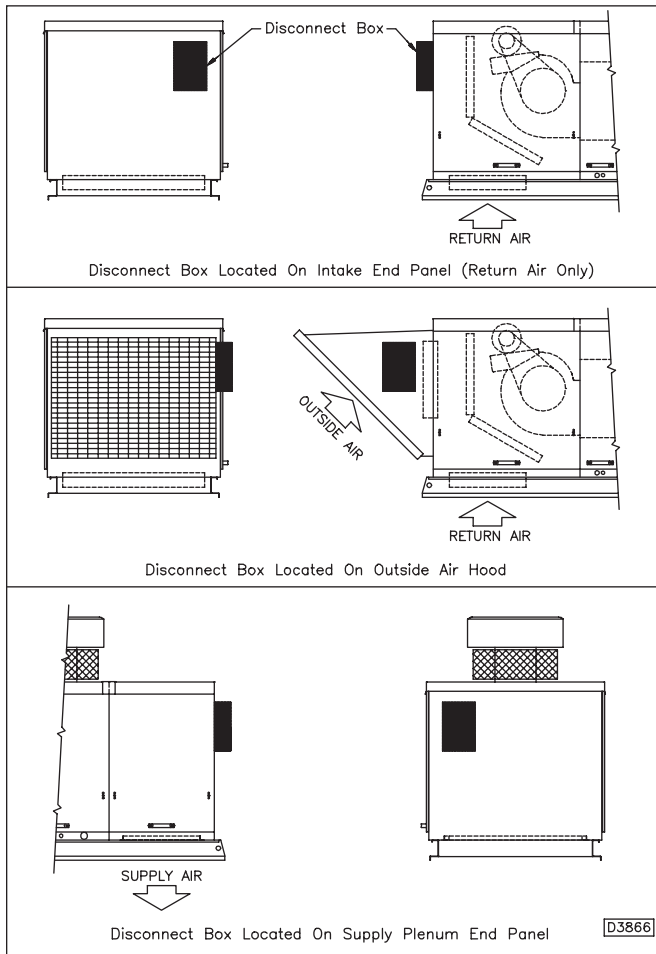

DX COIL EQUIPPED UNITS (OPTIONAL)

See Coil Installation/Maintenance Manual for Refrigerant Piping, Liquid and Suction Line Components, Refrigerant Charging and Thermal Expansion Valve Adjustment. Remove coil cabinet access door located next to blower section. Cut holes in fixed door to allow suction and liquid line passage. Provide weatherproof seal around suction and liquid lines at piping plate when installed.

The DX Coil has a 300 ft/min. (1.524 m/s) minimum and a 600 ft/min. (3.048 m/s) maximum velocity through the coil requirement. This is due to prevention of coil icing or condensate blow-off. To calculate the velocity through the coil, apply the following formula:

$$\text{Velocity through the coil} = \frac{\text{Cooling Air Flow in CFM (m}^3\text{/s)}}{\text{Coil Surface Area in ft}^2 \text{ (m}^2\text{)}}$$

Condensate Drain piping must have a P-trap in line immediately downstream of drain pan connection, external to the unit, to prevent possible outside air leakage into unit. The P-trap shall be of sufficient differential to overcome negative pressure of the indoor air blower. A minimum height difference of 2 inch is required (See Figure 12). Before unit operation begins, the P-trap must be primed with either water (summer) or glycol (winter).

CHILLED WATER COIL EQUIPPED UNITS (OPTIONAL)

See Coil Installation/Maintenance Manual for General Coil Piping Recommendations. Remove the coil cabinet door and cut holes in door to allow chilled water piping passage. Provide weatherproof seal around chilled water pipes at piping plate when installed.

The Chilled Water Coil has a 600 ft/min (3.048 m/s) maximum velocity through the coil requirement. This is due to prevention of condensate blow-off. To calculate the velocity through the coil apply the following formula:

$$\text{Velocity through the coil} = \frac{\text{Cooling Air Flow in CFM (m}^3\text{/s)}}{\text{Coil Surface Area in ft}^2 \text{ (m}^2\text{)}}$$

Condensate Drain piping must have a P-trap in line immediately downstream of drain pan connection, external to the unit, to prevent possible outside air leakage into unit. The P-trap shall be of sufficient differential to overcome negative pressure of the indoor air blower. A minimum height difference of 2 inch is required (See Figure 12). Before unit operation begins, prime P-trap with either water (summer) or glycol (winter).

Figure 12 - Drain Pan Connection

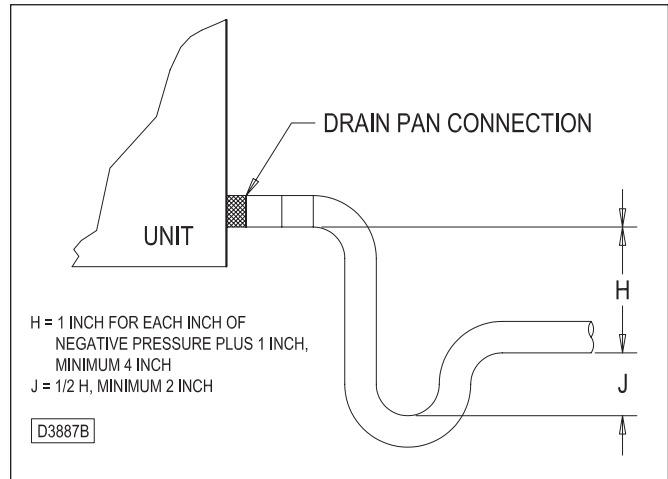

EVAPORATIVE COOLER EQUIPPED UNITS (OPTIONAL)

Refer to Evaporative Cooler Installation and Service Manual for water and electrical connections.

IV. OPERATION

GENERAL INFORMATION

Refer to Outdoor Rooftop Gas-Fired Duct Furnace Installation and Service Manual for specific information regarding the heating operation of this unit.

All units are equipped with a intermittent pilot ignition system. The pilot is lit and extinguished each cycle of unit heating operation.

Continuous Retry Models (Gas Type: 1 - Natural Gas, 2 - LP/Propane): Continuous retry models provide multiple trials for ignition; the ignitor will continue to spark and pilot gas will continue to flow until the pilot flame is proven. If the pilot is not lit or sensed before the end of the trial for ignition time, the control shuts off the spark and pilot gas (100% shutoff). There is a 5 minute delay before another ignition sequence is initiated. The pattern of ignition sequence followed by a 5 minute delay continues until the pilot lights and is proven or the call for heat ends. The 5 minute delay time can be bypassed by cycling the system thermostat or removing and restoring system power.

Lockout Models (Gas Type: 3 - Natural Gas with 100% Lockout): Lockout models provide a single trial for pilot ignition sequence. If the pilot flame is not lit and sensed before the end of the ignition trial time, the control shuts off the pilot valve (100% shutoff) and goes to lockout. The control remains in lockout until power to the control is cycled by the system thermostat or by removing and restoring system power.

The gas control system operates at 24 VAC and is supplied by a stepdown transformer found in the electrical cabinet that will match the unit line voltage specified. See Figure 10 for unit controls location.

Do not use a thermostatic fan control switch when either two-stage firing or modulated gas controls are used.

GAS CONTROL SYSTEM

The standard unit comes equipped for single stage operation. Unit heating operation is accomplished at full input. Each duct furnace is equipped with an individual ignition control system which consists of the following components: ignition control module, gas valve and pilot burner.

The **ignition control module** is the heart of the ignition control system. This control initiates all gas flow, provides means to light the pilot burner, proves and monitors the pilot burner operation.

The **gas valve** consists of two operators which provide gas to the pilot and main burners. Both operators are energized and de-energized by the ignition control module each heating cycle.

The **pilot burner** includes an ignitor and flame sense probe. The ignitor provides the spark, originating at the ignition control module, to light the pilot. The ignition control module proves and monitors the pilot flame through the flame sensing probe.

All units follow the same basic sequence of operation and is as follows:

1. Thermostat calls for heat.
Power vented units only: Drafter relay energizes drafter with call for heat.
2. Ignition control module energizes pilot operator of gas valve and initiates spark at ignitor of the pilot burner.
3. Pilot burner ignition is proven to the ignition control by the flame sense probe and sparking of the ignitor is discontinued.
4. Once pilot burner operation is proven, the ignition control module energizes the main burner operator of the gas valve, allowing gas flow to the main burners.
Power vented units only: In addition, drafter operation must be proven by drafter end switch before ignition control module energizes main burner operator of gas valve.
5. Approximately 60 seconds after the main burners light the fan time delay initiates fan operation.
6. Thermostat is satisfied and call for heat is removed.
Power vented units only: Drafter relay de-energizes drafter with removal of call for heat.
7. Ignition control module de-energizes pilot and main burner operators of the gas valve, ceasing all gas flow.
8. Approximately two minutes after satisfying the thermostat, fan operation ceases.

OPTIONAL GAS CONTROLS

These units are available with optional gas controls which will give either multi-stage or modulating operation. The sequence of operation of those units equipped with these optional gas controls differs only at what rate each duct furnace's main burners ignite and operate at or the order of duct furnace firing for those units equipped with two or three duct furnaces.

Two Stage Units: Two stages of heating; first stage is 40% of full rate, second stage is 100% of full rate. Main burner ignition is at first stage only.

Three Stage Units: *Dual duct furnace models:* First furnace is equipped with two stage heating; second furnace is equipped with a single stage heating but fired independantly giving three stages of heating.

Triple duct furnace models: Each duct furnace is equipped with single stage heating but fired independently, giving three stages. Each stage is 33% of the unit's full input rate. Duct furnace one will always light first and disengage last.

Four Stage Units: Dual duct furnace models only. Each duct furnace is equipped with two stage heating but fired independently, giving four stages. Each stage is 25% of the units full input rate. Duct furnace one will always light first and disengage last.

Six Stage Units: Triple duct furnace models only. Each duct furnace is equipped with two stage heating but fired independently giving six stages. Each stage is 16.5% of the units full input rate. Duct furnace one will always light first and disengage last.

Electronic Modulation Units: These units are equipped with a electronic modulating control which provides unit firing capabilities of 40 to 100% of the units full input rate. This control is found in the gas train downstream of the gas valve and allows main burner ignition only at the maximum rate. A thermostat with remote setpoint adjustment modulates the gas input.

Multi-Stage w/ Electronic Modulation Units: These dual and triple duct furnace models are equipped with an electronic modulating control on duct furnace one and single or two stage heating on each successive duct furnace. Furnace one (modulated) will fire first and disengage last. Additional stages of heat will engage after furnace one has fired at maximum modulation capability for the duration of the delay setting. The amount of modulation and each stage size depends upon unit size and the number of stages. See following chart.

Number of Stages	Modulation Capabilities (% of full input)	Stage Size (% of full input)
2	25 - 50	50
3	16.5 - 33	33
4	25 -50	25
6	16.5 - 33	16.5

AIR HANDLING REQUIREMENTS AND ADJUSTMENTS

▲ CAUTION Remove wooden shipping support from beneath blower housing of Blower Section to prevent possible unit damage or improper unit operation (if applicable).

Static Pressure through the unit should never exceed 2.0 inch W.C. (0.50 kPa). The standard unit is operated at a temperature rise range of 20 to 60°F (11 to 33°C). The high temperature rise model is operated at a temperature rise range of 60 to 90°F (33 to 50°C).

NOTICE: It is important that the final temperature leaving the unit does not exceed 160°F (71°C). When final air throughput adjustments are being made, a check of the discharge air temperature should be made after unit has operated for 15 to 20 minutes.

▲ CAUTION A unit should never be allowed to cycle on the primary limit for a prolonged period of time. It is a safety control to prevent a fire. If cycling on the primary limit is noted, corrective measures should be taken immediately. Failure to do so could result in unit damage or a fire.

NOTICE: At initial unit installation, unit should be started momentarily to confirm proper blower wheel rotation as the unit will deliver some air with the blower wheel running backwards.

Two basic air control systems can be used to deliver conditioned air to the occupied space: intermittent or constant fan operation.

Intermittent Fan Operation: The unit employs an air control system which utilizes a fan time delay relay to operate the fan while heating and the thermostat while cooling. Refer to unit wiring diagram.

Constant Fan Operation: The unit can be wired to give an air control system which constantly circulates air through the unit and occupied space with constant fan operation. Refer to unit wiring diagram.

NOTICE: Check blower belt tension. Proper belt tension is important to the long life of the belt and motor. Proper belt tension will allow the belt to be depressed 1/2 inch to 3/4 inch.

It is important that the blower motor and the blower wheel pulleys be in good alignment, with the motor and blower shafts parallel.

Belt tension must be adjusted to give approximately 3/4 inch deflection of the belt when finger pressure is applied to the middle of the belt (See Figure 13). Small changes in this tension may be necessary for optimum operation. Belts will stretch over a period of time, requiring an adjustment to this tension. See MAINTENANCE section for belt and pulley adjustments.

Figure 13 - Belt Tension Guide

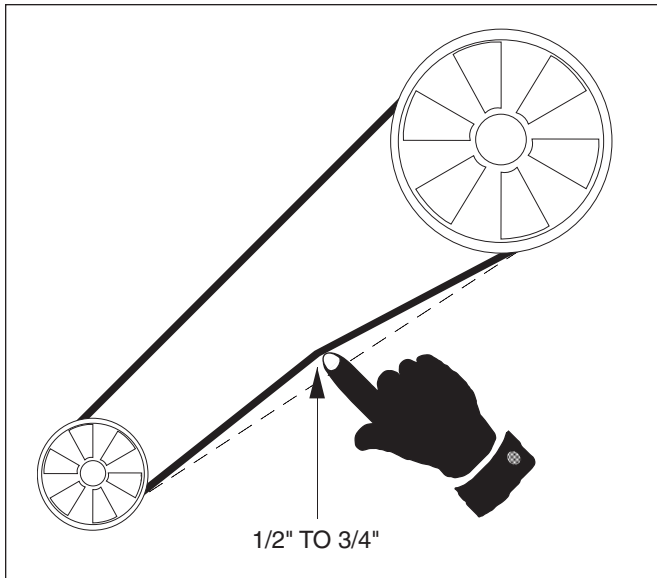

These units are set at the factory for the RPM required to meet the air volume (CFM) and external static pressure ordered. If the estimated external static is incorrect, or changes were made to the duct system, the blower RPM may need to be changed.

Both the Standard and High CFM Blowers use motors which are equipped with adjustable pitch pulleys. After removing belt(s), loosen the pulley set screw and remove the key, turn adjustable half of a pulley clockwise to increase RPM, or counter-clockwise to decrease RPM. Insert key, tighten set screw and replace belt(s). Adjust belt tension to give 1/2 inch to 3/4 inch belt play when depressed.

▲ CAUTION Blower motor full load amps should never be exceeded. Improper unit operation or motor failure could result.

After changing blower RPM, confirm blower motor full load amps have not been exceeded. See motor data plate for maximum full load amps.

LIGHTING

(Refer to Outdoor Duct Furnace Manual for all heating functions - general comments are as follows.) Purge the gas line to the unit of air before attempting to light the pilot. Check for gas leaks.

▲ WARNING Never use an open flame to detect gas leaks. Explosive conditions may exist which could result in personal injury or death.

This unit is equipped with an intermittent ignition system. A lighting instruction is attached to the unit. To set the intermittent ignition system into operation proceed as follows:

1. Turn on the gas valve(s) main manual valve.
2. Turn on electrical power. The unit is now under thermostat control.

3. Set thermostat to highest level. This will initiate the sequence of operation detailed in the Gas Control System section. Check main burners for operation.
4. Set thermostat to lowest level. This will interrupt power to the ignition control and shut off gas. Confirm pilot and main burners have been extinguished.
5. Set the thermostat to the desired setting.

For complete unit shutdown, proceed as follows:

1. Turn off the gas valve(s) main manual valve.
2. Set thermostat to lowest setting.
3. Shut off all electric power.

GAS INPUT ADJUSTMENT

When shipped from the factory, all units are equipped for the average heat content of the gas which is stamped on the unit rating plate.

▲ CAUTION Since the heat content of gas varies by locality, the input must be checked after installation of the unit. If the unit is overfired it will shorten the life of the heat exchanger. Never exceed the input on the rating plate.

For an accurate input rate measurement the following meter method should be used to determine unit input rate. If the meter method is not possible, a manifold pressure check should be made.

Meter Method of Checking Input Rate

1. Obtain the heating value of the gas from the local utility or gas dealer. This should be in units of Btu/ft³ (MJ/m³).
2. Determine the gas flow rate as shown in the following example. EXAMPLE: Assume this unit has a input rate of 250,000 Btu/hr (73.2 kW) and the heating value of the gas is 1000 Btu/ft³ (37.3 MJ/m³).

$$\begin{aligned} \text{Gas Flow Rate} &= \frac{250,000 \text{ Btu/hr (73.2 kW)}}{1000 \text{ Btu/ft}^3 (37.3 \text{ MJ/m}^3) \times 60 \text{ min/hr}} \\ &= 4.17 \text{ ft}^3/\text{min (1.974 L/s)} \end{aligned}$$

3. Before determining the gas flow rate to the unit, all other gas appliances connected to the same meter must be turned off.
4. Fire unit according to instructions.
5. After approximately 15 minutes of unit operation, determine volume of gas used in five minutes of unit operation. For the Example above the unit should use 4.17 ft³/min x 5 min or 20.8 ft³ (1.97 L/s x 5 min x 60 s/min = 591L) of gas. Minor input adjustments can be made by removing pressure regulator cap and turning regulator clockwise to increase input or counter clockwise to decrease input. Any appreciable adjustment in input rate should be made by reorificing.

Method to Check Manifold Pressure

1. Close the manual valve of unit gas valve.
2. Install a 1/8 inch pipe connection in the tapped hole provided in the gas valve body near outlet of the valve.
3. Attach manometer to 1/8 inch pipe connection by means of a rubber hose.
4. Fire unit according to instructions and observe the pressure and confirm it matches the unit manifold pressure from the unit rating plate.
5. Small variations in the manifold pressure can be made by means of the gas valve pressure regulator. Remove pressure regulator cap and turn regulator clockwise to increase pressure or counter-clockwise to decrease pressure.

PILOT ADJUSTMENT

1. Disconnect wire from terminal marked MV at gas valve.
2. Provide call for heat.
3. Pilot adjustment is found on the gas valve. Remove pilot adjustment cap.
4. Adjust the pilot screw to provide properly sized flame.
5. A proper pilot burner flame is a soft steady flame that envelopes 3/8 to 1/2 inch (9.5 to 12.7mm) of the flame sense probe tip.
6. Replace the pilot adjustment cap.
7. Reconnect wire to terminal MV.

PRIMARY AIR SHUTTER ADJUSTMENT

After the unit has been in operation for at least 15 minutes, adjust the primary air flow to the burners. Turn the friction-locked manually rotated air shutters clockwise to close, counter clockwise to open. For correct air adjustment, close the air shutter until yellow tips in the flame appear. Then open the air shutter to the point just beyond the position where yellow tipping disappears.

CONTROLS

Primary Limit Control: The primary limit control is a factory installed component surface mounted in the inlet airstream at the end of the heat exchanger. When the temperature reaches the limit setpoint, normally caused by insufficient air throughput, all gas is shutoff. The limit control has an automatic reset and once the unit has cooled, it will reset itself. This is a safety control and if cycling on the primary limit is noted, corrective action must be taken. See unit wiring diagram for electrical location. This control must never be bypassed. Upon completion of unit installation, the primary limit must be checked for proper operation. This can be accomplished by removing power to the indoor air blower and a call for heat.

Draftor End Switch: This switch is located at the end of the draftor motor and is integral to the motor. The switch, which is normally open, will close when draftor motor attains the minimum speed for proper combustion allowing main burner operation. The pilot burner will light without a proven draftor end switch. See unit wiring diagram for electrical location.

Clogged Filter Switch: (Optional) The clogged filter switch monitors the pressure differential across the air filters. If this pressure differential becomes too great, the switch will alert of this condition. At this point the air filters must either be cleaned or replaced. The switch will reset itself.

Firestat: (Optional) Located in either the return airstream, the supply airstream, or both, this control monitors temperatures with setpoints which are field adjustable. If the temperature exceeds the setpoint, the control will cease unit operation. To resume unit operation, a manual reset of this control is required.

Freezestat: (Optional) Located in either the return airstream, the supply airstream, or both, this control monitors temperatures with setpoints which are field adjustable. If the temperature does not exceed the setpoint, the control will cease unit operation.

Pre-Purge Delay: (Optional, PV Only) On a call for heat, the pre-purge relay provides each furnace an independent 60 second pre-purge mode where the power venter is energized prior to beginning the ignition sequence.

V. START UP

Before starting the unit, use the "Installation Check Sheet" (located at the end of this manual) and read the Outdoor Duct Furnace Manual entirely in conjunction with the procedures outlined below to ensure that the unit is completely and properly installed and ready for start up.

▲ WARNING **Installer's responsibility! All safety controls must be checked! Check and test the operational functions of all safety devices supplied with this unit. Failure to do so could result in unsafe conditions, and may result in death, serious injury or property damage.**

1. Inspect all wiring connections; connections should be clean and tight. **Trace circuits to insure that actual wiring agrees with the "as wired" diagrams provided with the unit.** Information in the wiring diagram title block should match the data appearing on the unit nameplate.
2. Lubricate all electrical motors according to the manufacturer's recommendations.
3. Verify that the system switch is in the OFF position.
4. Check unit supply voltage to ensure that it is within the utilization range.
5. Inspect the interior of the unit; remove any debris or tools which may be present.

Starting Unit in Heating Mode

1. Close the unit disconnect switch which provides power to the unit.

▲ WARNING High voltage is present in some areas of the unit (primarily the main electrical cabinet) with the unit disconnect switch closed. Failure to exercise caution when working in the presence of energized electrical components may result in injury or death from electrical shock.

2. Set the thermostat/switching subbase as indicated below:
 - a. position the heating system switch at either HEAT or AUTO;
 - b. set the fan switch to AUTO.
3. Place the system switch in the ON position.

With the thermostat calling for heat, unit operation is automatic.

Starting Unit in Cooling Mode

1. Close the unit disconnect switch which provides power to the unit.

▲ WARNING High voltage is present in some areas of the unit (primarily the main electrical cabinet) with the unit disconnect switch closed. Failure to exercise caution when working in the presence of energized electrical components may result in injury or death from electrical shock.

2. Set the thermostat/switching subbase as indicated below:
 - a. position the cooling system switch at either COOL or AUTO;
 - b. set the fan switch to AUTO.
3. Place the system switch in the ON position.

With the thermostat calling for cooling, unit operation is automatic.

Final Checkout

Run the unit sequentially through its stages of heating and cooling. Once proper unit operation is verified, perform these final steps:

1. Inspect unit for debris and/or misplaced tools and hardware.
2. Be sure all gas valves and controls are in the operating position if the unit will be operating immediately.
3. Cycle unit on all safety controls to verify proper unit operation.
4. Confirm proper operating control (thermostat or ductstat) operation by cycling unit.
5. Secure all exterior panels in place.

VI. MAINTENANCE

▲ WARNING Open all disconnect switches and secure in that position before servicing unit. Failure to do so may result in personal injury or death from electrical shock.

▲ WARNING Gas tightness of the safety shut-off valves must be checked on at least an annual basis.

To check gas tightness of the safety shut-off valves, turn off the manual valve upstream of the appliance combination control. Remove the 1/8 inch pipe plug on the inlet side of the combination control and connect a manometer to that tapping. Turn the manual valve on to apply pressure to the combination control. Note the pressure reading on the manometer, then turn the valve off. A loss of pressure indicates a leak. If a leak is detected, use a soap solution to check all threaded connections. If no leak is found, combination control is faulty and must be replaced before putting appliance back in service.

These units have been developed for outdoor installation. Maintenance is required and it is suggested that the following unit servicing and inspections be performed routinely. Also read in entirety and refer to the Outdoor Duct Furnace Manual for maintenance requirements.

▲ WARNING Service technician's responsibility! All safety controls must be checked! Check and test the operational functions of all safety devices supplied with this unit. Failure to do so could result in unsafe conditions, and may result in death, serious injury or property damage.

Inspect area near unit to be sure that there is no combustible material located within the minimum clearance requirements (See Figure 2). Service panels provide easy access to the gas controls (located in duct furnace section), the blower compartment, the electrical cabinet and the supply plenum. To remove the service door from any of these compartments, refer to access panel removal section in beginning of this manual.

The pilot burner can be serviced by removing the pilot plate from the main burner drawer assembly.

To remove the main burner drawer assembly (also refer to Outdoor Rooftop Duct Furnace Installation and Service Manual) for servicing the burners, proceed as follows:

1. Shut off the gas supply at the gas shutoff valve and electrical power to the unit.
2. Break the union upstream of duct furnace gas valve and loosen the union external to the furnace; swing downward the piping to clear drawer.
3. Disconnect duct furnace gas valve wiring taking note of all wire locations. Disconnect ignitor and flame sensing probe wires at ignition control module and any other wires.

4. Remove the locking screws holding the burner drawer assembly in position.
5. Slide the burner drawer out of the duct furnace.
6. Removal of burners is accomplished by sliding burner towards manifold, compressing locating spring, until the rear of the burner clears slot in back of burner drawer.
7. With burner drawer removed from duct furnace, inspect the inside surfaces of the heat exchanger. Wire brush if necessary.
8. Remove any dirt, dust or other foreign matter from the burners using a wire brush and/or compressed air. Insure all parts of the burner are unobstructed. Inspect and clean pilot burner if necessary.
9. Reassemble the duct furnace by replacing all parts in order.
10. Light unit per the unit lighting instructions.
11. Check the burner adjustment. See the "Primary Air Adjustment" section of this manual.
12. Check all gas control valves and pipe connections for leaks.

▲ WARNING Under no circumstance should combustible material be located within the specified clearances. Failure to provide proper clearance could result in personal injury or property damage from fire.

13. Check the operation of the duct furnace gas valve by lowering the setting of the thermostat, stopping the operation of the duct furnace. The duct furnace gas valve should close, extinguishing the pilot and main burner flames.
14. Inspect and service the blower section of the system.

The unit should be thoroughly checked before the start and at the end of each heating and cooling season.

1. Motors and belts should be inspected.
2. Tighten belts if loose.
3. Check and clean DX or Chilled Water coil twice yearly, if unit is so equipped per manufacturer's service manual. Chilled Water coil must be winterized at beginning of heating season (i.e. drain water from coil per manufacturer's instructions).
4. Check air throughput at beginning of heating season to confirm unit operation is within the specified temperature rise range.
5. At beginning of heating season clear Condensate Drain Pan and P-trap of water if unit is equipped with DX or Chilled water coil. Clean out drain pan and fill P-trap with a non-toxic glycol solution.
6. Evaporative cooler must be cleaned and maintained per manufacturer's instruction frequently during the operating season.
7. Inspect Control Dampers during periodic maintenance. Damper pivot points should be cleaned to ensure free damper operation.
8. Blower wheels should be checked periodically for dirt build-up on blades. Clean as required.

FILTERS

It is recommended that air filters be changed or cleaned at least four times a year. More frequent attention to filters is required if the air being handled by the unit is unusually dirty. Air flow reduction, caused by the dirty air filters, will increase the discharge air temperature and may cause unit cycling on the primary limit.

Filters (by others) should be serviced regularly and changed or washed when necessary to maintain the required air throughput. In a dusty environment, filters may clog up in less than one month.

High CFM Blower Air Filter Size Requirements

Unit Input	Number of Filters Required	
	16 x 20 (in)	20 x 20 (in)
200 MBtuh (58.6 kW)		8
250 MBtuh (73.2 kW)		8
300 MBtuh (87.9 kW)	8	4
350 MBtuh (102.6 kW)	8	4
400 MBtuh (117.2 kW)		12
500 MBtuh (146.5 kW)		8
600 MBtuh (175.8 kW)	8	4
700 MBtuh (205.1 kW)	8	4
800 MBtuh (234.4 kW)		12
1,200 MBtuh (351.6kW)		12

Standard CFM Blower Air Filter Size Requirements

Unit Input	Number of Filters Required	
	16 x 20 (in)	20 x 20 (in)
100 MBtuh (29.3 kW)	4	
150 MBtuh (44.0 kW)	4	
200 MBtuh (58.6 kW)		4
250 MBtuh (73.2 kW)		4
300 MBtuh (87.9 kW)	4	2
350 MBtuh (102.6 kW)	4	2
400 MBtuh (117.2 kW)		6
500 MBtuh (146.5 kW)		4
600 MBtuh (175.8 kW)	4	2
700 MBtuh (205.1 kW)	4	2
800 MBtuh (234.4 kW)		6

AIR BLOWER

Belt Tension Adjustment Standard CFM Blower belt tension can be adjusted by loosening motor mounting bolts marked A (See Figure 14). To tighten belt, slide motor down motor mounting bracket and re-fasten motor to mounting bracket.

High CFM Blower belt(s) tension can be adjusted by first loosening motor mounting plate bolts marked A (See Figure 14). To tighten belt tension, turn belt tension adjustment screws marked B (See Figure 14) counter-clockwise. To loosen belt tension, turn clockwise. Once belt tension has been adjusted, re-fasten motor mounting plate bolts.

Blower RPM Adjustment

To adjust blower RPM:

1. Loosen and remove belt(s).
2. Match driver pulley to one found in Figure 15.
3. Loosen setscrew(s) marked A.
4. If driver pulley is equipped with external key, marked B, remove.
5. Adjust driver pulley pitch diameter for desired speed by opening (slower) or closing (faster) moving parts by half or full turns. Do not open sheave past point where flange projects past the hub end.
6. If driver pulley is equipped with external key, marked B, replace.
7. Tighten setscrew(s) marked A.
8. Replace and retension belt(s).
9. Realign drive if necessary.

Figure 14

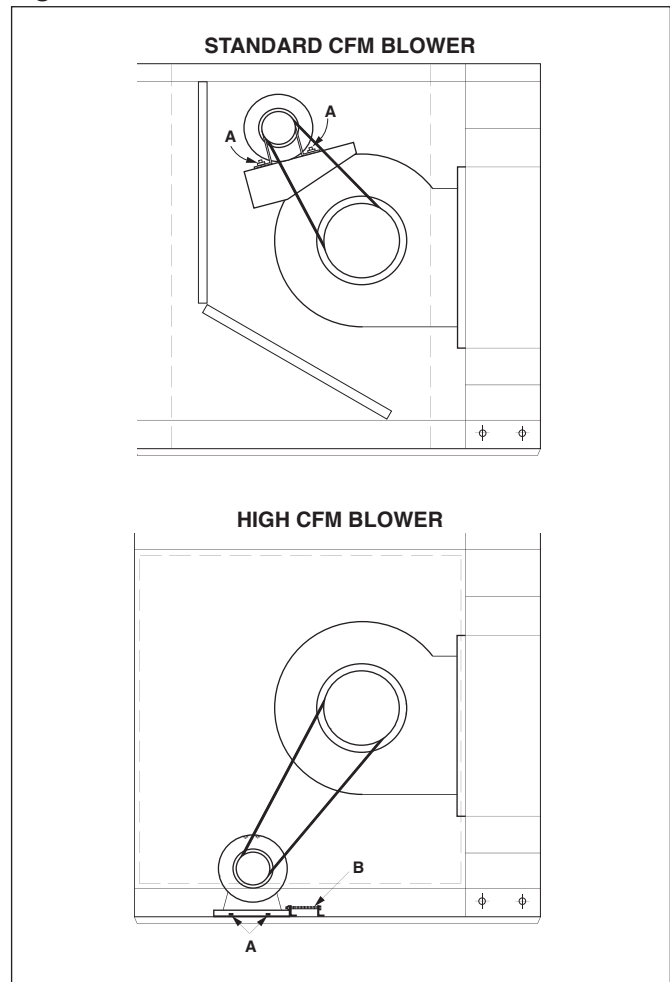
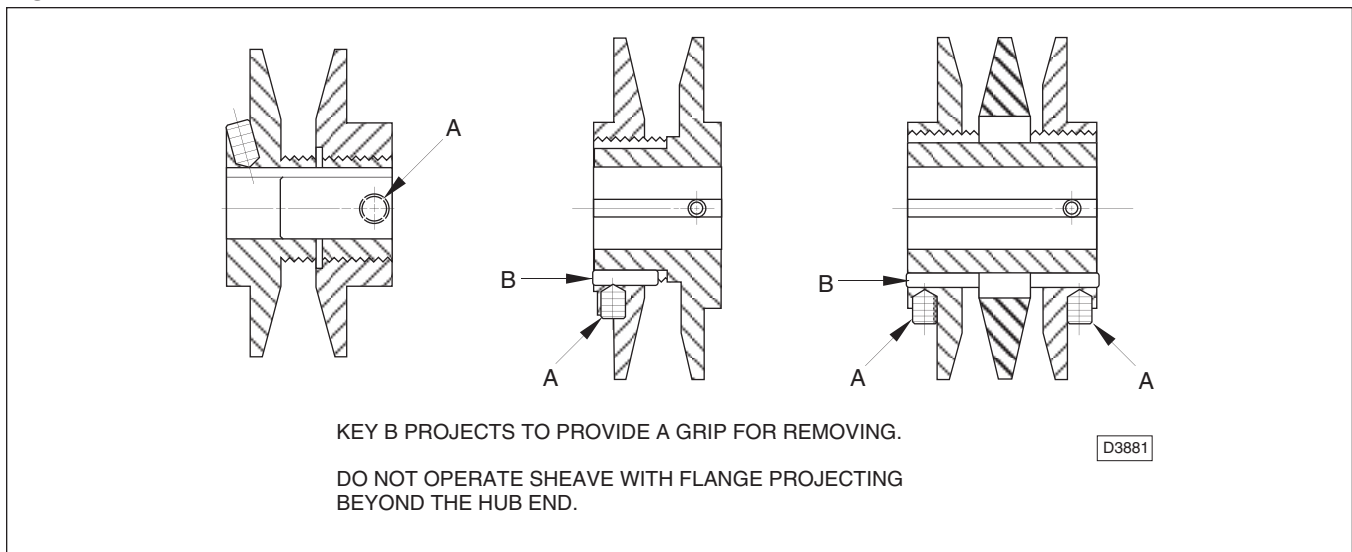

Figure 15



VII. TROUBLESHOOTING

For troubleshooting of the duct furnace, refer to Outdoor Rooftop Gas-Fired Duct Furnace Installation and Service Manual. For Evaporative Cooler/Cooling Coil equipped units, refer to these specific manuals for additional troubleshooting guides.

For additional troubleshooting, see following Troubleshooting Guide.

TRUBLESHOOTING GUIDE – AIR BLOWER

PROBLEM	PROBABLE CAUSE	SOLUTION
1. Noise	Blower Wheel Hitting Scroll Side	<ul style="list-style-type: none"> a. Blower Wheel not centered in blower housing. b. Damaged blower housing. c. Damaged blower wheel. d. Shaft loose in blower bearing. e. Blower Wheel loose on shaft. f. Blower bearing loose in bearing support.
	Blower Wheel Hitting Cutoff	<ul style="list-style-type: none"> a. Cutoff not secure in blower housing. b. Cutoff damaged. c. Cutoff improperly positioned.
	Drive	<ul style="list-style-type: none"> a. Pulley not tight on shaft (motor and/or blower wheel). b. Belts too loose. Adjust for belt stretching after 48 hours of operation. c. Belts too tight. d. Belts wrong cross section. e. Belts not matched in length on multi-belt drive. f. Variable pitch pulleys not adjusted so each pulley has same pitch diameter (multi-belt drives). g. Misaligned pulleys. h. Belts worn. i. Motor or motor base loose. j. Belts oily or dirty k. Improper drive selection
	Bearing	<ul style="list-style-type: none"> a. Defective bearing. b. Needs lubrication. c. Loose on bearing support. d. Loose on shaft. e. Seals misaligned. f. Foreign material in bearing. g. Worn bearing. h. Fretting corrosion between inner race and shaft.
	Shaft Seal Squeal	<ul style="list-style-type: none"> a. Needs lubrication. b. Misaligned.

PROBLEM	PROBABLE CAUSE	SOLUTION	
1. Noise	Blower Wheel	<ul style="list-style-type: none"> a. Loose on shaft. b. Defective blower wheel. Do not run blower. Contact manufacturer. c. Unbalanced. d. Worn as a result of contact with abrasive or corrosive material. 	
	Housing	<ul style="list-style-type: none"> a. Foreign material in housing. b. Cutoff of other part loose (rattling during operation). 	
	Electrical	<ul style="list-style-type: none"> a. Lead-in cable not secure. b. AC hum in motor or relay c. Starting relay chatter. d. Noisy motor bearings. e. Single phasing a 3 phase motor. 	
	Shaft	<ul style="list-style-type: none"> a. Bent. b. Undersized. May cause noise at blower wheel, bearings or pulley. c. If more than two bearings are on a shaft, they must be properly aligned. 	
	High Air Velocity	<ul style="list-style-type: none"> a. Duct work too small for application. b. Blower selection too small for application. c. Registers or grilles too small for application. d. Cooling coil with insufficient face area for application. 	
	Obstruction in High Velocity Air Stream may cause Rattle or Pure Tone Whistle	<ul style="list-style-type: none"> a. Dampers. b. Registers. c. Grilles. d. Sharp elbows. e. Sudden expansion in duct work. f. Sudden contraction in duct work. g. Turning vanes. 	
	Pulsation or Surge	<ul style="list-style-type: none"> a. Blower too large for application. b. Ducts vibrate at same frequency as blower pulsations. 	
	Rattles and/or Rumbles	<ul style="list-style-type: none"> a. Vibrating duct work. b. Vibrating cabinet parts. c. Vibrating parts not isolated from building. 	
	2. CFM Low - Insufficient Air Flow	Blower	<ul style="list-style-type: none"> a. Forward curved blower wheel installed backwards. b. Blower operating backwards. c. Cutoff missing or improperly installed. d. Blower wheel RPM too low.
		Duct System	<ul style="list-style-type: none"> a. Actual system is more restrictive than expected. b. Dampers closed. c. Registers closed. d. Leaks in supply duct.

PROBLEM	PROBABLE CAUSE	SOLUTION
2. CFM Low Insufficient Air Flow	Filters	Dirty or clogged.
	Coil - DX or Chilled Water	Dirty or clogged.
	Obstructions in High Velocity Air Stream	a. Obstruction near unit outlet. b. Sharp elbows near unit outlet. c. Improperly designed turning vanes. d. Projections, dampers or other obstructions in part of duct system where air velocity is high.
3. CFM High - Too Much Air Flow	System	a. Oversized duct work. b. Access door open. c. Registers or grilles not installed. d. Filters not in place. e. System resistance lower than anticipated.
	Blower	Blower RPM is too great.
4. Blower Does Not Operate	Installation	a. Incorrect electrical connection. b. Wrong voltage. c. Blown fuse.
	Unit	a. Broken belt(s). b. Loose pulleys. c. Power to unit is disconnected. d. Motor overload protector has broken circuit. e. Optional thermostats, firestats, freezestats may lockout blower operation if set incorrect.

TROUBLESHOOTING GUIDE – ELECTRIC MOTORS

PROBLEM	PROBABLE CAUSE	SOLUTION
1. Motor	Blown fuse or open circuit breaker.	Replace fuse or reset circuit breaker.
	Overload trip.	Check and reset, if manual.
	Improper line connections.	Check connections to unit wiring diagram.
	Improper current supply.	Check to determine that power supply agrees with motor nameplate specifications.
	Mechanical failure. Check bearings.	Determine that motor and drive turn freely.
	Motor overloaded.	Reduce load or replace motor.
	With a 3 phase power source, one phase may be open.	Check line for open phase.
	Defective capacitor.	Replace capacitor.
2. Motor Stalls	Wrong application.	Consult manufacturer.
	Overloaded motor.	Reduce load or replace motor.
	Low line voltage.	Check across AC line and correct if possible.

PROBLEM	PROBABLE CAUSE	SOLUTION
3. Motor runs and then dies down.	Partial loss of line voltage.	Check for loose connections. Determine adequacy of main power supply.
4. Motor does not come up to speed.	Motor undersized for application.	Replace with larger motor.
	Voltage too low at motor terminals.	Check across AC line and correct if possible.
	Line wiring to motor is too small.	Install larger line wiring.
5. Motor takes too long to accelerate.	Excessive load.	Replace with larger motor.
	Loose connection.	Check connections and tighten where necessary.
6. Wrong Rotation (3 Phase)	Improperly wired to AC line (wrong sequence of phases).	Check unit wiring diagram. Reverse any two line voltage connections.
7. Motor Overheats	Motor overloaded.	Replace with larger motor.
	Motor ventilation clogged.	Clean motor.
	Motor (3 phase) may have open phase.	Check to insure that all connections are tight.
	Line voltage too high or too low.	Check across AC line and correct if possible.
	Worn blower bearings.	Replace blower bearings.
8. Motor Vibrates	Motor mounting bolts loose.	Tighten mounting bolts.
	Driven equipment unbalanced.	Balance driven equipment.
	Worn motor bearings.	Replace motor.
	3 phase Motor running on single phase.	Check for open circuit and correct.
	Bent motor shaft.	Replace motor.
9. Rapid Motor Bearing Wear	Excessive overhung load due to over tensioned belt.	Reduce belt tension.

TROUBLESHOOTING GUIDE – FAN ASSEMBLY

PROBLEM	PROBABLE CAUSE	SOLUTION
1. Short Belt Life	Spin burns from belt slippage.	Tension belt.
	High ambient temperature.	Use Gripnotch belts.
	Grease or oil on belts.	Clean belts and pulleys.
	Worn pulleys.	Replace pulleys.
	Belt Misalignment.	Realign drive.
2. Belts turn over in grooves	Damaged belt.	Replace belt.
	Excessive vibration.	Tension belts. Replace belts if damaged.
	Worn pulleys.	Replace pulleys.
	Pulley Misalignment.	Realign drive.
3. Belt Squeal	Excessive load.	High starting load. Retension drive.
4. Belt Breakage	Foreign material in drive.	Provide drive guard.
	Belts damaged during installation.	Replace belts.
	Extreme Overload.	Eliminate overload.
5. Excessive Vibration	Damaged belt cord section.	Replace belts.
	Loose belts.	Tension drive.
	Belts improperly tensioned.	Tension drive with slack of each belt on the same side of drive.

PROBLEM	PROBABLE CAUSE	SOLUTION
6. Belts mismatched after service	Belts improperly tensioned, causing more stretch of some belts than others.	Replace belts and tension drive with slack of each belt on the same side of the drive.
	Old belts and new belts used on same drive.	Replace with new belts.
	Different brand name belts used on same drive.	Replace with a set of Machine Matched Belts.
	Driver and driven shafts shifted from parallel.	Realign drive.
	Belt cord section damaged during installation.	Replace belts and install properly.
7. Drive fails to adjust	Fretting corrosion (drive allowed to operate at one speed over a period of time).	Driver pulley must be disassembled, cleaned and lubricated, then reassembled.

TROUBLESHOOTING GUIDE – DX COOLING COIL

PROBLEM	PROBABLE CAUSE	SOLUTION
1. No or Insufficient Cooling	Coil icing.	a. Low liquid line pressure.* b. Thermal expansion valve.** c. Low air flow across coil.
	Air binding.	Purge and charge system.
	Thermal expansion valve.**	a. Bulb mounted at incorrect location. b. Bulb not secured properly.
	Insufficient air flow.	a. See air blower troubleshooting. b. Clogged coil
	Air bypassing coil.	Caulk safe off.
	Undersized system, demand exceeding cooling system capacity.	Replace system.*
	Too much outside air.	Check outside air dampers.
	Refrigerant leak.	Determine leak location and correct.
	Low liquid pressure.	Determine cause and correct.*
2. Water in Conditioned Air	Exceeding coil face velocity - 600 fpm. Drain pan p-trap clogged.	Reduce unit air flow. Clean pan and p-trap.

* Refer to condensing unit installation and service manual.

**Refer to thermal expansion valve installation instruction.

TROUBLESHOOTING GUIDE – CHILLED WATER COOLING COIL

PROBLEM	PROBABLE CAUSE	SOLUTION
1. No or Insufficient Cooling	Circulating pump failure.	Repair or replace pump.*
	Chilled water temperature not cool enough.	Check chiller.*
	Air binding (air in coil).	Bleed coil.
	Insufficient chilled water flow.	a. Circulating pump capacity is inadequate.* b. System piping losses too great.
	Insufficient air flow.	a. See air blower troubleshooting. b. Clogged coil
	Air bypassing coil.	Caulk safe off.
	Undersized system, demand exceeding cooling system capacity.	Replace system.*
	Too much outside air.	Check outside air dampers.
2. Water in Conditioned Air	Exceeding coil face velocity - 600 fpm.	Reduce unit air flow.
	Drain pan P-trap clogged.	Clean pan and p-trap.

*Refer to Manufacturer's Installation and Service Manual.

VIII. REPLACEMENT PARTS

To order Replacement Parts, please provide the following information to your local representative:

- Model Number
- Serial Number
- Part description and Number as shown in Replacement Parts Literature

If further assistance is required, please contact the manufacturer's customer service department

IX. SERVICE NOTE

Due to the many configurations, options and voltage characteristics available on Rooftop Packaged Units, the information provided in this manual is somewhat general in context. Should user or service organization incur a problem, the nature of which is not herein, we urge you to contact the manufacturer. It would be of great assistance to us if you can provide the model and serial numbers and the wiring diagram number, as well as the access type.

X. LIMITED WARRANTY

All components are warranted by the manufacturer to be free from defects in material and workmanship for period of one (1) year from the date of shipment from the manufacturing plant.

The manufacturer will repair or replace, at its option, any component which, upon inspection, it finds to be defective, provided that the Rooftop Packaged Unit has been operated within its listed capacity, has been installed in accordance with all furnished instruction, has not been misused or subjected to neglect and has received reasonable and necessary maintenance. This warranty does not cover labor costs or other costs incurred in repairing, removing, installing, servicing or handling of parts or completed products.

This Warranty does not cover loss due to corrosion by chemicals precipitated in the air such as halogenated hydrocarbons. The manufacturer will in no event be liable for incidental or consequential damages of any kind whatsoever.

Written permission is required prior to the return of defective components. All returns must be sent with all transportation charges prepaid to the plant designated in the written permission. This warranty is extended only to the original owner of the Rooftop Package Unit.

XI. UNIT NET & SHIP WEIGHTS

**NOTE: ALL UNIT WEIGHTS ARE LESS MOTOR, OUTSIDE AIR HOOD AND COOLING COILS W/ DRAIN PAN
FOR UNITS ORDERED WITH DOUBLE WALL CONSTRUCTION (OPTIONAL) ADD AN ADDITIONAL 10% OF THE BASE UNIT WEIGHT**

RT = NATURAL VENT, PV = POWER VENT (REFER TO MODEL # DESCRIPTION)

ROOF TOP ARRANGEMENT [RA] "A"				
	NET WT. SHIP.WT.		NET WT. SHIP.WT.	
RT-10	256	367	PV-10	262 373
RT-15	307	418	PV-15	298 409
RT-20	365	484	PV-20	356 475
RT-25	405	524	PV-25	395 514
RT-30	469	596	PV-30	455 582
RT-35	510	637	PV-35	495 622
RT-40	558	690	PV-40	543 675
RT-50	795	952	PV-50	777 934
RT-60	914	1081	PV-60	885 1052
RT-70	994	1161	PV-70	964 1131
RT-80	1087	1259	PV-80	1058 1230
RT-12	1617	1820	PV-12	1573 1776

ROOF TOP ARRANGEMENT [RA] "B"				
	NET WT. SHIP.WT.		NET WT. SHIP.WT.	
RT-10	576	742	PV-10	583 749
RT-15	627	793	PV-15	619 785
RT-20	740	916	PV-20	731 907
RT-25	781	957	PV-25	771 947
RT-30	907	1092	PV-30	893 1078
RT-35	958	1143	PV-35	943 1128
RT-40	1032	1222	PV-40	1018 1208
RT-50	1195	1423	PV-50	1175 1403
RT-60	1377	1616	PV-60	1349 1588
RT-70	1468	1707	PV-70	1438 1677
RT-80	1589	1833	PV-80	1561 1805

ROOF TOP ARRANGEMENT [RA] "C"				
	NET WT. SHIP.WT.		NET WT. SHIP.WT.	
RT-10	705	923	PV-10	712 930
RT-15	756	974	PV-15	748 966
RT-20	884	1112	PV-20	875 1103
RT-25	925	1153	PV-25	915 1143
RT-30	1068	1307	PV-30	1054 1293
RT-35	1117	1356	PV-35	1102 1341
RT-40	1201	1445	PV-40	1187 1431
RT-50	1345	1598	PV-50	1325 1578
RT-60	1546	1811	PV-60	1518 1783
RT-70	1636	1901	PV-70	1606 1871
RT-80	1765	2034	PV-80	1737 2006

ROOF TOP ARRANGEMENT [RA] "D"				
	NET WT. SHIP.WT.		NET WT. SHIP.WT.	
RT-10	705	904	PV-10	712 911
RT-15	757	956	PV-15	749 948
RT-20	893	1102	PV-20	884 1093
RT-25	935	1144	PV-25	925 1134
RT-30	1083	1301	PV-30	1069 1287
RT-35	1134	1352	PV-35	1119 1337
RT-40	1220	1443	PV-40	1206 1429
RT-50	1348	1595	PV-50	1328 1575
RT-60	1554	1812	PV-60	1526 1784
RT-70	1644	1902	PV-70	1614 1872
RT-80	1777	2040	PV-80	1749 2012

ROOF TOP ARRANGEMENT [RA] "E"				
	NET WT. SHIP.WT.		NET WT. SHIP.WT.	
RT-10	835	1072	PV-10	842 1079
RT-15	886	1123	PV-15	878 1115
RT-20	1037	1284	PV-20	1028 1275
RT-25	1078	1325	PV-25	1068 1315
RT-30	1244	1502	PV-30	1230 1488
RT-35	1294	1552	PV-35	1279 1537
RT-40	1389	1652	PV-40	1375 1638
RT-50	1499	1785	PV-50	1479 1765
RT-60	1722	2020	PV-60	1694 1992
RT-70	1812	2110	PV-70	1782 2080
RT-80	1953	2257	PV-80	1925 2229

ROOF TOP ARRANGEMENT [RA] "G"				
	NET WT. SHIP.WT.		NET WT. SHIP.WT.	
RT-20	982	1206	PV-20	973 1197
RT-25	1025	1249	PV-25	1015 1239
RT-30	1218	1452	PV-30	1204 1438
RT-35	1261	1495	PV-35	1246 1480
RT-40	1343	1583	PV-40	1329 1569
RT-50	1427	1689	PV-50	1407 1669
RT-60	1677	1951	PV-60	1649 1923
RT-70	1759	2033	PV-70	1729 2003
RT-80	1886	2166	PV-80	1858 2138
RT-12	2420	2741	PV-12	2376 2697

ROOF TOP ARRANGEMENT [RA] "J"				
	NET WT. SHIP.WT.		NET WT. SHIP.WT.	
RT-20	1116	1378	PV-20	1107 1369
RT-25	1157	1419	PV-25	1147 1409
RT-30	1367	1641	PV-30	1353 1627
RT-35	1409	1683	PV-35	1394 1668
RT-40	1499	1779	PV-40	1485 1765
RT-50	1597	1898	PV-50	1577 1878
RT-60	1863	2177	PV-60	1835 2149
RT-70	1944	2258	PV-70	1914 2228
RT-80	2079	2400	PV-80	2051 2372
RT-12	2620	2981	PV-12	2576 2937

ROOF TOP ARRANGEMENT [RA] "K"				
	NET WT. SHIP.WT.		NET WT. SHIP.WT.	
RT-10	886	1137	PV-10	893 1144
RT-15	937	1188	PV-15	929 1180
RT-20	1132	1394	PV-20	1123 1385
RT-25	1174	1436	PV-25	1164 1426
RT-30	1385	1659	PV-30	1371 1645
RT-35	1428	1702	PV-35	1413 1687
RT-40	1519	1799	PV-40	1505 1785
RT-50	1614	1915	PV-50	1594 1934
RT-60	1881	2195	PV-60	1853 2207
RT-70	1964	2278	PV-70	1934 2288
RT-80	2099	2420	PV-80	2071 2432

ROOF TOP ARRANGEMENT [RA] "L"

	NET WT.	SHIP.WT.		NET WT.	SHIP.WT.
RT-10	1055	1344	PV-10	1062	1351
RT-15	1106	1395	PV-15	1098	1387
RT-20	1316	1617	PV-20	1307	1608
RT-25	1358	1659	PV-25	1348	1649
RT-30	1589	1903	PV-30	1575	1889
RT-35	1630	1944	PV-35	1615	1929
RT-40	1730	2051	PV-40	1716	2037
RT-50	1756	2096	PV-50	1736	2076
RT-60	2043	2397	PV-60	2015	2369
RT-70	2125	2479	PV-70	2095	2449
RT-80	2269	2630	PV-80	2241	2602

OUTSIDE AIR HOOD

W/BIRD SCREEN WEIGHT ADDER	
Capacity [CA]	Weight
10	43
15	43
20	51
25	51
30	59
35	59
40	63
50	51
60	59
70	59
80	63

ROOF TOP ARRANGEMENT [RA] "M"

Capacity [CA]	NET WT.	SHIP.WT.
20	403	616
40	513	744

ROOF TOP ARRANGEMENT [RA] "N"

Capacity [CA]	NET WT.	SHIP.WT.
20	529	705
40	665	855

ROOF TOP ARRANGEMENT [RA] "P"

Capacity [CA]	NET WT.	SHIP.WT.
20	609	822
40	769	1000

ROOF TOP ARRANGEMENT [RA] "R"

Capacity [CA]	NET WT.	SHIP.WT.
20	735	959
40	921	1161

ROOF TOP ARRANGEMENT [RA] "S"

Capacity [CA]	NET WT.	SHIP.WT.
20	635	847
40	793	1023

ROOF TOP ARRANGEMENT [RA] "T"

Capacity [CA]	NET WT.	SHIP.WT.
20	788	1012
40	967	1207

ROOF TOP ARRANGEMENT [RA] "U"

Capacity [CA]	NET WT.	SHIP.WT.
20	797	1021
40	987	1227

ROOF TOP ARRANGEMENT [RA] "W"

Capacity [CA]	NET WT.	SHIP.WT.
20	936	1198
40	1152	1432

Double Wall Construction Adder

For units ordered with double wall construction: add an additional 10% to the base unit weight.

Cooling Coil Weight Adder

(CA) Capacity	DX COIL		CHILLED WATER COIL	
	4 Row	6 Row	4 Row	6 Row
10, 15	97 lbs.	132 lbs.	75 lbs.	102 lbs.
20, 25, 50	126 lbs.	177 lbs.	98 lbs.	135 lbs.
30, 35, 60, 70	165 lbs.	229 lbs.	125 lbs.	176 lbs.
40, 80	177 lbs.	249 lbs.	135 lbs.	196 lbs.

MOTOR SHIPPING WEIGHTS (APPROXIMATE)

	1 - (115/1/60)				2 - (208/1/60)				3 - (230/1/60)			
	1	2	3	4	1	2	3	4	1	2	3	4
	ODP	TE	PEODP	PETE	ODP	TE	PEODP	PETE	ODP	TE	PEODP	PETE
1/2 HP	20	21	29	30	21		29		21	21	29	30
3/4 HP	23	31	38	41	23	31	38		23	31	38	41
1 HP	32	32	40	44	32	32			32	32	40	44
1-1/2 HP	35	48	47	57	35	48			35	48	47	57
2 HP	42	67	65	64	43	67			42	48	65	64
3 HP	78	72			78	72			78	72		90
5 HP					87				87	99	95	
7-1/2 HP					134	138			134	138		
10 HP										161		
15 HP												
	4 - (208/3/60)				5 - (230/3/60)				6 - (460/3/60)			
	1	2	3	4	1	2	3	4	1	2	3	4
	ODP	TE	PEODP	PETE	ODP	TE	PEODP	PETE	ODP	TE	PEODP	PETE
1/2 HP	20	22	22	22	20	22	22	22	20	22	22	22
3/4 HP	27	26	27		27	26	27	31	27	26	27	31
1 HP	24	26	36	37	24	26	36	37	24	26	36	37
1-1/2 HP	31	34	40	42	31	34	40	42	31	34	40	42
2 HP	39		46	49	39		46	49	39		46	49
3 HP	47		69	69	47		69	69	47		69	69
5 HP			76	77			76	77			76	77
7-1/2 HP			117	136			117	136			117	136
10 HP			128	158			128	158			128	158
15 HP			217	255			217	255			217	255
	7 - (575/3/60)											
	1	2	3	4								
	ODP	TE	PEODP	PETE								
1/2 HP	22	22										
3/4 HP	20	22										
1 HP	28	27	33	38								
1-1/2 HP			40	42								
2 HP			46	48								
3 HP			66	100								
5 HP			74	91								
7-1/2 HP			114	143								
10 HP			145	153								
15 HP			234	348								

Motor Type (MT) Legend:

- ODP - Open Drip Proof
- TE - Totally Enclosed
- PEODP - Premium Efficiency Open Drip Proof
- PETE - Premium Efficiency Totally Enclosed

XII. CENTER OF GRAVITY

Figure 16

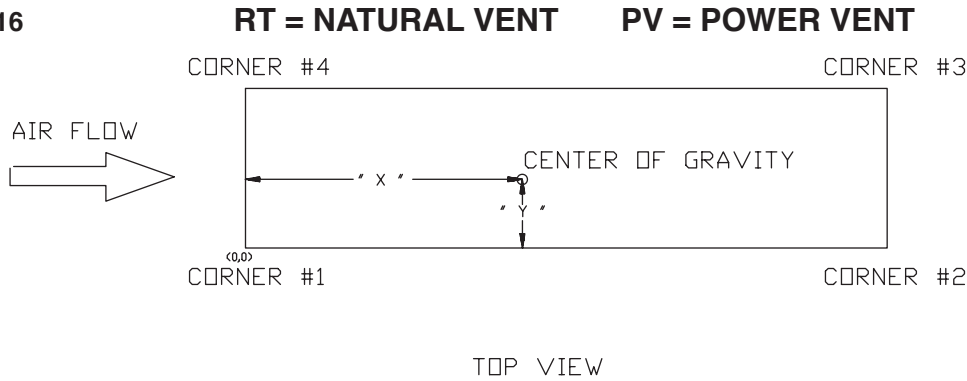

Values Based on Average Motor Weight
(Actual Center of Gravity and Corner Weights For Specific Motor Size are Available Upon Request)

Unit Type, Capacity	Width	Length	ARRANGEMENT "B" Without Outside Air Hood								ARRANGEMENT "B" With Outside Air Hood			
			Center of Gravity		Corner Weights (lbs)				Center of Gravity		Corner Weights (lbs)			
			X-Coor	Y-Coor	Corner #1	Corner #2	Corner #3	Corner #4	X-Coor	Y-Coor	Corner #1	Corner #2	Corner #3	Corner #4
RT10	32.75	72	35.9	15.4	161	160	141	142	32.6	15.4	187	154	138	167
PV10	32.75	72	35.8	15.4	161	159	141	142	32.5	15.4	187	154	137	167
RT15	32.75	72	36.9	15.4	163	171	153	145	33.7	15.5	190	166	149	170
PV15	32.75	72	36.7	15.4	163	169	150	145	33.5	15.5	189	164	147	170
RT20	43.75	72	36.6	20.6	196	202	179	174	33.3	20.7	227	196	175	203
PV20	43.75	72	36.2	20.6	195	196	174	173	32.9	20.7	226	190	170	202
RT25	43.75	72	37.3	20.6	198	213	190	177	34.1	20.7	230	207	186	206
PV25	43.75	72	37.0	20.6	197	207	185	175	33.7	20.7	229	201	181	205
RT30	54.75	72	37.7	25.3	232	255	218	198	34.5	25.4	269	247	214	232
PV30	54.75	72	37.2	25.2	230	246	209	196	33.9	25.3	267	238	205	230
RT35	54.75	72	37.7	25.1	245	269	228	207	34.6	25.3	282	261	224	241
PV35	54.75	72	37.2	25.1	243	260	219	205	34.1	25.2	280	252	215	239
RT40	60.25	72	38.2	27.9	254	287	248	219	35.1	28.0	294	279	243	256
PV40	60.25	72	37.8	27.9	253	278	239	217	34.6	28.0	292	270	234	253
RT50	43.75	98	51.2	20.8	278	304	276	253	48.3	20.9	308	299	274	281
PV50	43.75	98	50.7	20.8	275	294	267	250	47.8	20.9	305	290	264	278
RT60	54.75	98	51.4	25.7	324	356	315	286	48.5	25.8	359	351	312	319
PV60	54.75	98	50.7	25.6	318	340	299	280	47.7	25.7	353	335	296	313
RT70	54.75	98	51.6	25.6	341	378	333	300	48.8	25.7	376	373	329	332
PV70	54.75	98	50.9	25.6	336	362	317	294	48.0	25.6	371	356	314	326
RT80	60.25	98	52.2	28.4	358	407	363	319	49.4	28.5	396	401	360	354
PV80	60.25	98	51.6	28.3	353	391	347	313	48.7	28.4	390	385	344	348
RT12	60.25	124	65.7	28.7	467	525	476	423	63.1	28.7	503	520	474	457
PV12	60.25	124	65.0	28.6	456	503	454	412	62.3	28.7	493	498	452	447

Unit Type, Capacity	Width	Length	ARRANGEMENT "C" Without Outside Air Hood								ARRANGEMENT "C" With Outside Air Hood			
			Center of Gravity		Corner Weights (lbs)				Center of Gravity		Corner Weights (lbs)			
			X-Coor	Y-Coor	Corner #1	Corner #2	Corner #3	Corner #4	X-Coor	Y-Coor	Corner #1	Corner #2	Corner #3	Corner #4
RT10	32.75	98	43.3	15.5	210	166	150	190	40.1	15.6	236	163	148	214
PV10	32.75	98	43.3	15.5	210	166	150	190	40.0	15.6	235	162	147	214
RT15	32.75	98	43.9	15.6	216	175	158	196	40.7	15.6	241	171	156	220
PV15	32.75	98	43.8	15.6	215	173	157	195	40.6	15.6	240	169	154	219
RT20	43.75	98	43.5	20.8	257	205	185	233	40.3	20.8	287	200	182	261
PV20	43.75	98	43.2	20.8	255	201	181	230	40.0	20.8	285	196	178	259
RT25	43.75	98	43.8	20.8	263	212	192	238	40.7	20.9	293	208	189	267
PV25	43.75	98	43.6	20.8	260	208	189	236	40.5	20.9	290	204	186	264
RT30	54.75	98	44.1	25.5	308	251	220	269	41.0	25.6	343	246	217	302
PV30	54.75	98	43.8	25.5	304	245	213	265	40.6	25.6	339	239	210	297
RT35	54.75	98	43.8	25.4	324	261	226	281	40.8	25.5	359	256	223	313
PV35	54.75	98	43.5	25.4	320	255	220	276	40.4	25.5	355	249	217	309
RT40	60.25	98	44.0	28.2	340	277	244	299	41.0	28.3	378	271	240	334
PV40	60.25	98	43.7	28.2	336	271	237	295	40.7	28.3	374	265	234	330
RT50	43.75	124	57.3	20.9	346	296	272	317	54.4	21.0	375	293	270	345
PV50	43.75	124	57.0	20.9	340	289	265	312	54.1	21.0	369	285	263	340
RT60	54.75	124	57.4	25.9	402	346	310	360	54.5	25.9	436	342	307	392
PV60	54.75	124	57.0	25.8	393	334	298	350	54.0	25.9	427	329	295	382
RT70	54.75	124	57.3	25.8	428	368	327	381	54.6	25.9	462	363	325	413
PV70	54.75	124	56.8	25.7	420	355	315	372	54.1	25.8	454	350	312	404
RT80	60.25	124	57.6	28.6	449	389	350	404	54.8	28.6	485	384	347	438
PV80	60.25	124	56.8	28.5	442	373	335	397	54.0	28.6	478	369	333	431
RT12	60.25	150	70.8	28.8	559	500	456	510	68.2	28.8	594	469	454	544
PV12	60.25	150	70.3	28.7	545	481	438	496	67.7	28.8	580	477	436	530

Unit Type, Capacity	Width	Length	ARRANGEMENT "D" Without Water							ARRANGEMENT "D" With Water						
			Center of Gravity		Corner Weights (lbs)				Center of Gravity		Corner Weights (lbs)					
			X-Coor	Y-Coor	Corner #1	Corner #2	Corner #3	Corner #4	X-Coor	Y-Coor	Corner #1	Corner #2	Corner #3	Corner #4		
RT10	32.75	108	25.6	15.5	251	138	125	227	17.4	15.7	358	114	105	330		
PV10	32.75	108	25.5	15.5	251	138	124	226	17.4	15.7	358	114	105	330		
RT15	32.75	108	26.8	15.6	253	150	136	230	18.7	15.7	360	126	117	333		
PV15	32.75	108	26.6	15.4	256	150	133	226	18.5	15.6	363	125	113	329		
RT20	43.75	108	26.3	20.8	305	176	159	276	17.6	21.0	446	144	133	412		
PV20	43.75	108	25.9	20.8	304	171	154	275	17.1	21.0	445	139	128	411		
RT25	43.75	108	27.2	20.8	308	187	170	279	18.5	21.0	449	156	144	415		
PV25	43.75	108	26.8	20.8	307	182	165	278	18.1	21.0	448	150	139	414		
RT30	54.75	108	27.5	25.6	361	223	196	316	18.3	25.9	539	183	165	485		
PV30	54.75	108	26.9	25.5	359	214	187	314	17.6	25.9	537	174	156	483		
RT35	54.75	108	27.9	25.5	374	237	206	325	18.9	25.8	552	196	175	493		
PV35	54.75	108	27.3	25.4	372	228	197	322	18.3	25.8	551	187	167	491		
RT40	60.25	108	28.3	28.2	392	354	224	346	18.9	28.6	588	210	190	532		
PV40	60.25	108	27.7	28.2	390	245	415	343	18.3	28.6	586	200	181	539		
RT50	43.75	134	41.9	21.0	381	285	262	350	33.0	21.1	514	261	243	479		
PV50	43.75	134	41.3	20.9	378	275	253	347	32.4	21.1	511	252	234	475		
RT60	54.75	134	42.0	25.9	444	333	299	398	32.5	26.1	612	303	276	558		
PV60	54.75	134	41.1	25.8	438	317	283	392	31.5	26.1	606	287	261	552		
RT70	54.75	134	42.6	25.8	462	355	316	411	33.3	26.0	630	325	294	571		
PV70	54.75	134	41.8	25.8	456	339	301	405	32.4	26.0	624	308	279	565		
RT80	60.25	134	43.1	28.6	487	383	345	439	33.6	28.8	671	350	321	616		
PV80	60.25	134	42.4	28.5	481	367	330	433	32.7	28.8	666	333	305	609		

Unit Type, Capacity	Width	Length	ARRANGEMENT "E" Without Water							ARRANGEMENT "E" With Water						
			Center of Gravity		Corner Weights (lbs)				Center of Gravity		Corner Weights (lbs)					
			X-Coor	Y-Coor	Corner #1	Corner #2	Corner #3	Corner #4	X-Coor	Y-Coor	Corner #1	Corner #2	Corner #3	Corner #4		
RT10	32.75	108	33.0	15.6	300	152	139	274	24.8	15.8	400	135	125	371		
PV10	32.75	108	33.0	15.6	299	152	139	274	24.7	15.8	399	135	125	370		
RT15	32.75	108	33.8	15.7	305	161	148	280	25.6	15.8	405	143	133	377		
PV15	32.75	108	33.7	15.7	304	159	146	279	25.5	15.8	404	142	132	376		
RT20	43.75	108	33.2	20.9	365	187	171	334	24.3	21.1	498	164	152	463		
PV20	43.75	108	32.8	20.9	363	183	167	332	23.9	21.1	496	160	148	461		
RT25	43.75	108	33.8	20.9	371	195	179	340	24.9	21.1	504	172	160	469		
PV25	43.75	108	33.5	20.9	368	191	175	337	24.6	21.1	501	168	156	466		
RT30	54.75	108	34.0	25.7	434	231	204	384	24.5	26.0	602	201	181	544		
PV30	54.75	108	33.5	25.7	430	224	198	380	24.0	26.0	598	194	175	540		
RT35	54.75	108	34.0	25.6	452	240	210	395	24.8	25.9	620	210	188	555		
PV35	54.75	108	33.6	25.5	447	234	204	391	24.3	25.9	615	203	182	550		
RT40	60.25	108	34.2	28.3	476	255	226	422	24.7	28.7	660	222	201	599		
PV40	60.25	108	33.8	28.3	472	248	220	418	24.2	28.6	656	215	195	594		
RT50	43.75	134	47.8	21.0	450	283	261	416	38.9	21.1	579	264	247	540		
PV50	43.75	134	47.4	21.0	445	275	254	411	38.3	21.1	573	257	239	535		
RT60	54.75	134	47.9	25.9	524	330	297	472	38.3	26.1	686	306	280	627		
PV60	54.75	134	47.3	25.9	515	317	283	462	37.5	26.1	677	293	267	617		
RT70	54.75	134	48.3	25.9	551	351	314	493	39.0	26.1	713	327	297	648		
PV70	54.75	134	47.7	25.8	542	339	302	484	38.3	26.0	704	314	285	638		
RT80	60.25	134	48.5	28.6	579	371	336	524	38.8	28.8	757	345	317	695		
PV80	60.25	134	47.5	28.6	573	356	321	517	37.8	28.8	750	330	302	688		

Unit Type, Capacity	Width	Length	ARRANGEMENT "G" Without Outside Air Hood							ARRANGEMENT "G" With Outside Air Hood						
			Center of Gravity		Corner Weights (lbs)				Center of Gravity		Corner Weights (lbs)					
			X-Coor	Y-Coor	Corner #1	Corner #2	Corner #3	Corner #4	X-Coor	Y-Coor	Corner #1	Corner #2	Corner #3	Corner #4		
RT20	43.75	108	60.0	20.7	223	279	252	201	56.3	20.8	253	275	249	229		
PV20	43.75	108	59.6	20.7	223	274	246	200	55.8	20.8	252	269	244	228		
RT25	43.75	108	61.0	20.8	230	298	270	208	57.3	20.8	259	293	267	236		
PV25	43.75	108	60.5	20.8	229	292	264	207	56.9	20.8	259	288	262	235		
RT30	54.75	108	62.1	25.4	267	361	313	232	58.4	25.5	302	355	310	264		
PV30	54.75	108	61.5	25.4	266	351	304	230	57.7	25.5	301	346	301	262		
RT35	54.75	108	61.5	25.1	284	375	318	240	58.0	25.2	319	369	315	272		
PV35	54.75	108	60.9	25.1	283	365	308	239	57.3	25.2	318	359	306	271		
RT40	60.25	108	61.7	27.9	297	395	341	256	58.1	28.0	334	389	338	290		
PV40	60.25	108	61.1	27.9	295	385	332	255	57.5	28.0	333	379	329	289		
RT50	43.75	134	75.6	20.9	303	392	360	278	72.3	21.0	332	389	358	305		
PV50	43.75	134	75.0	20.9	301	382	350	275	71.6	20.9	330	378	348	303		
RT60	54.75	134	76.3	25.7	352	465	413	313	72.9	25.8	386	461	411	344		
PV60	54.75	134	75.4	25.7	348	448	396	308	72.0	25.8	382	443	394	340		
RT70	54.75	134	76.1	25.5	372	489	427	325	72.9	25.6	406	484	425	356		
PV70	54.75	134	75.2	25.5	368	471	410	320	72.0	25.6	402	466	408	352		
RT80	60.25	134	76.2	28.3	393	518	460	349	73.0	28.4	430	514	458	383		
PV80	60.25	134	75.4	28.3	389	500	443	344	72.1	28.3	426	496	441	378		
RT12	60.25	160	90.4	28.6	492	640	577	444	87.5	28.6	527	636	575	477		
PV12	60.25	160	89.5	28.5	485	615	553	435	86.5	28.6	520	611	551	469		

Unit Type, Capacity	Width	Length	ARRANGEMENT "J" Without Outside Air Hood						ARRANGEMENT "J" With Outside Air Hood					
			Center of Gravity		Corner Weights (lbs)				Center of Gravity		Corner Weights (lbs)			
			X-Coor	Y-Coor	Corner #1	Corner #2	Corner #3	Corner #4	X-Coor	Y-Coor	Corner #1	Corner #2	Corner #3	Corner #4
RT20	43.75	134	66.8	20.9	283	281	257	259	63.1	20.9	312	278	255	286
PV20	43.75	134	66.4	20.9	282	277	252	257	62.7	20.9	311	273	250	284
RT25	43.75	134	67.3	20.9	294	296	271	269	63.8	21.0	323	293	269	297
PV25	43.75	134	67.0	20.9	292	292	267	267	63.4	20.9	321	288	265	295
RT30	54.75	134	68.1	25.6	344	356	313	303	64.6	25.7	378	351	311	334
PV30	54.75	134	67.7	25.6	341	348	306	299	64.1	25.7	375	344	304	331
RT35	54.75	134	67.3	25.4	363	366	316	313	63.9	25.4	397	362	314	344
PV35	54.75	134	66.9	25.3	360	358	309	310	63.4	25.4	394	354	307	341
RT40	60.25	134	67.5	28.2	380	386	339	334	64.0	28.2	416	381	336	367
PV40	60.25	134	67.1	28.1	377	378	331	330	63.6	28.2	413	373	329	364
RT50	43.75	160	81.4	21.0	372	385	356	344	78.2	21.0	400	383	354	371
PV50	43.75	160	81.0	21.0	368	377	348	339	77.7	21.0	396	374	346	367
RT60	54.75	160	82.7	25.9	430	459	412	385	79.4	25.9	463	456	410	417
PV60	54.75	160	82.0	25.8	423	445	397	378	78.6	25.9	456	441	396	409
RT70	54.75	160	81.8	25.7	454	475	419	401	78.7	25.7	487	471	417	432
PV70	54.75	198	81.1	25.6	447	460	405	393	77.9	25.7	480	456	403	425
RT80	60.25	160	81.9	28.5	482	505	452	431	78.8	28.5	517	501	451	465
PV80	60.25	160	81.3	28.4	475	490	438	424	78.1	28.5	510	486	436	458
RT12	60.25	186	96.0	28.7	584	624	566	530	93.1	28.7	619	620	564	563
PV12	60.25	186	93.2	28.5	544	547	491	488	90.0	28.6	579	543	489	521

Unit Type, Capacity	Width	Length	ARRANGEMENT "K" with Chilled Water Coil Without Outside Air Hood						ARRANGEMENT "K" with Chilled Water Coil With Outside Air Hood					
			Center of Gravity		Corner Weights (lbs)				Center of Gravity		Corner Weights (lbs)			
			X-Coor	Y-Coor	Corner #1	Corner #2	Corner #3	Corner #4	X-Coor	Y-Coor	Corner #1	Corner #2	Corner #3	Corner #4
RT10	32.75	134	70.1	15.8	254	279	260	237	66.7	15.8	278	276	258	260
PV10	32.75	134	70.0	15.8	254	278	259	237	66.7	15.8	278	276	257	260
RT15	32.75	134	71.4	15.9	254	291	274	240	68.1	15.9	279	288	272	263
PV15	32.75	134	71.2	15.9	254	288	271	239	67.8	15.9	278	286	270	263
RT20	43.75	134	72.2	21.1	287	336	312	267	68.7	21.1	316	332	310	295
PV20	43.75	134	71.7	21.1	287	330	306	266	68.2	21.1	315	327	304	294
RT25	43.75	134	73.2	21.1	293	354	330	274	69.8	21.1	322	351	328	301
PV25	43.75	134	72.8	21.1	293	348	324	273	69.3	21.1	322	345	322	301
RT30	54.75	134	74.6	26.1	331	417	380	302	71.1	26.2	365	412	377	334
PV30	54.75	134	73.9	26.1	330	407	370	301	70.4	26.1	364	402	368	333
RT35	54.75	134	74.6	25.9	344	432	389	309	71.2	26.0	378	428	386	341
PV35	54.75	134	73.9	25.9	343	422	379	308	70.5	26.0	377	418	377	340
RT40	60.25	134	74.9	28.7	358	454	413	326	71.4	28.8	394	450	410	360
PV40	60.25	134	74.3	28.7	357	444	403	324	70.8	28.7	393	440	401	358
RT50	43.75	160	87.9	21.1	379	462	431	353	84.8	21.1	407	459	429	380
PV50	43.75	160	87.2	21.1	377	452	420	351	84.1	21.1	405	449	418	378
RT60	54.75	160	88.6	26.0	433	536	486	392	85.4	26.1	466	533	484	423
PV60	54.75	160	87.5	26.0	430	518	468	388	84.2	26.0	463	514	466	419
RT70	54.75	160	89.5	25.8	446	566	505	398	86.4	25.9	479	562	504	429
PV70	54.75	160	88.5	25.8	443	548	488	394	85.3	25.8	476	544	486	426
RT80	60.25	160	90.2	28.6	465	601	543	420	87.0	28.6	500	597	541	454
PV80	60.25	160	89.2	28.6	462	582	525	416	86.0	28.6	479	578	523	450

Unit Type, Capacity	Width	Length	ARRANGEMENT "K" with DX Cooling Coil Without Outside Air Hood						ARRANGEMENT "K" with DX Cooling Coil With Outside Air Hood					
			Center of Gravity		Corner Weights (lbs)				Center of Gravity		Corner Weights (lbs)			
			X-Coor	Y-Coor	Corner #1	Corner #2	Corner #3	Corner #4	X-Coor	Y-Coor	Corner #1	Corner #2	Corner #3	Corner #4
RT10	32.75	134	73.1	15.7	217	260	240	200	69.2	15.7	241	257	238	223
PV10	32.75	134	73.0	15.7	217	259	239	200	69.1	15.7	241	257	238	223
RT15	32.75	134	74.5	15.8	217	272	254	203	70.6	15.9	241	269	252	226
PV15	32.75	134	74.3	15.8	217	269	252	203	70.4	15.8	241	267	250	226
RT20	43.75	134	75.0	21.0	249	317	292	230	71.0	21.0	278	313	290	258
PV20	43.75	134	74.4	21.0	249	311	287	229	70.4	21.0	278	308	284	257
RT25	43.75	134	76.0	21.0	256	335	310	237	72.1	21.1	285	332	308	265
PV25	43.75	134	75.5	21.0	255	329	305	236	71.6	21.1	284	326	303	264
RT30	54.75	134	74.6	26.1	331	417	380	302	71.1	26.2	365	412	377	334
PV30	54.75	134	73.9	26.1	330	407	370	301	70.4	26.1	364	402	368	333
RT35	54.75	134	77.0	25.8	306	413	369	273	73.2	25.9	340	409	367	304
PV35	54.75	134	76.3	25.8	305	403	359	272	72.4	25.9	339	399	357	303
RT40	60.25	134	77.2	28.6	320	436	393	289	73.4	28.6	356	431	391	323
PV40	60.25	134	76.6	28.6	319	426	383	288	72.7	28.6	355	421	381	322
RT50	43.75	160	91.1	21.0	338	447	414	313	87.7	21.1	366	444	412	340
PV50	43.75	160	90.4	21.0	336	436	403	311	86.9	21.1	364	433	402	338
RT60	54.75	160	91.3	25.9	392	521	469	352	87.9	26.0	425	517	467	383
PV60	54.75	160	90.3	25.9	388	503	451	348	86.7	25.9	422	499	449	380
RT70	54.75	160	92.2	25.7	405	551	488	359	88.8	25.8	438	547	487	390
PV70	54.75	160	91.2	25.7	402	532	470	355	87.8	25.7	435	528	469	386
RT80	60.25	160	92.8	28.5	424	586	526	381	89.4	28.6	459	582	524	414
PV80	60.25	160	91.9	28.5	421	567	508	377	88.4	28.5	456	563	506	410

Unit Type, Capacity	Width	Length	ARRANGEMENT "L" with Chilled Water Coil Without Outside Air Hood							ARRANGEMENT "L" with Chilled Water Coil With Outside Air Hood						
			Center of Gravity		Corner Weights (lbs)				Center of Gravity		Corner Weights (lbs)					
			X-Coor	Y-Coor	Corner #1	Corner #2	Corner #3	Corner #4	X-Coor	Y-Coor	Corner #1	Corner #2	Corner #3	Corner #4		
RT10	32.75	160	74.6	15.8	314	274	257	294	71.3	15.9	337	272	255	317		
PV10	32.75	160	74.5	15.8	314	273	256	294	71.3	15.9	337	271	255	317		
RT15	32.75	160	77.8	15.9	307	291	276	291	74.6	15.9	331	289	274	314		
PV15	32.75	160	77.7	15.9	307	289	274	291	74.4	15.9	331	287	273	314		
RT20	43.75	160	78.6	21.1	348	337	315	326	75.2	21.2	377	334	313	353		
PV20	43.75	160	78.2	21.1	347	332	310	324	74.8	21.2	375	329	309	352		
RT25	43.75	160	79.2	21.2	359	351	330	337	75.8	21.2	387	348	328	364		
PV25	43.75	160	78.8	21.2	357	346	325	335	75.4	21.2	385	344	323	362		
RT30	54.75	160	80.4	26.2	408	412	379	375	77.0	26.3	440	408	377	406		
PV30	54.75	160	79.8	26.2	405	403	371	372	76.4	26.3	438	400	369	403		
RT35	54.75	160	80.2	26.1	422	424	385	384	76.8	26.1	455	421	383	415		
PV35	54.75	160	79.6	26.0	420	416	377	381	76.2	26.1	453	412	375	412		
RT40	60.25	160	80.5	28.8	441	446	409	404	77.1	28.9	476	443	407	438		
PV40	60.25	160	80.0	28.8	438	438	401	402	76.5	28.9	474	434	399	435		
RT50	43.75	186	93.8	21.2	450	458	428	421	90.7	21.2	478	455	427	448		
PV50	43.75	186	93.2	21.1	447	448	419	418	90.1	21.2	475	446	418	445		
RT60	54.75	186	94.9	26.1	512	533	486	467	91.8	26.2	544	530	485	498		
PV60	54.75	186	94.1	26.1	506	518	471	460	90.9	26.1	538	514	469	491		
RT70	54.75	186	94.9	25.9	532	555	499	479	91.9	26.0	565	552	498	510		
PV70	54.75	186	94.1	25.9	527	539	484	473	91.0	25.9	559	536	483	504		
RT80	60.25	186	95.5	28.9	554	585	539	510	92.4	28.9	588	581	537	543		
PV80	60.25	186	94.8	28.9	548	569	523	504	91.6	28.9	583	566	522	537		

Unit Type, Capacity	Width	Length	ARRANGEMENT "L" with DX Cooling Coil Without Outside Air Hood							ARRANGEMENT "L" with DX Cooling Coil With Outside Air Hood						
			Center of Gravity		Corner Weights (lbs)				Center of Gravity		Corner Weights (lbs)					
			X-Coor	Y-Coor	Corner #1	Corner #2	Corner #3	Corner #4	X-Coor	Y-Coor	Corner #1	Corner #2	Corner #3	Corner #4		
RT10	32.75	160	77.7	15.8	273	258	240	254	74.0	15.8	297	256	239	277		
PV10	32.75	160	77.7	15.8	273	257	240	254	74.0	15.8	297	255	238	277		
RT15	32.75	160	81.3	15.9	267	276	260	251	77.5	15.9	291	273	258	274		
PV15	32.75	160	81.1	15.9	266	274	258	251	77.3	15.9	290	271	256	274		
RT20	43.75	160	81.7	21.1	308	321	298	286	77.8	21.1	336	318	297	313		
PV20	43.75	160	81.3	21.1	306	316	294	284	77.4	21.1	335	313	292	312		
RT25	43.75	160	82.2	21.1	318	335	313	297	78.4	21.2	346	333	311	324		
PV25	43.75	160	81.8	21.1	316	331	308	295	78.0	21.1	345	328	307	322		
RT30	54.75	160	83.1	26.1	367	396	362	335	79.3	26.2	400	393	360	366		
PV30	54.75	160	82.5	26.1	364	388	354	332	78.7	26.2	397	384	352	364		
RT35	54.75	160	82.8	26.0	381	409	368	344	79.1	26.0	414	405	367	375		
PV35	54.75	160	82.2	25.9	379	400	360	341	78.5	26.0	412	397	359	372		
RT40	60.25	160	83.0	28.7	400	431	392	365	79.2	28.8	435	427	390	398		
PV40	60.25	160	82.4	28.7	398	422	384	362	78.7	28.8	433	419	382	395		
RT50	43.75	186	97.1	21.1	407	444	414	379	93.7	21.1	435	442	413	406		
PV50	43.75	186	96.5	21.1	403	435	405	376	93.1	21.1	431	433	404	403		
RT60	54.75	186	97.9	26.0	468	520	472	425	94.5	26.1	501	517	470	456		
PV60	54.75	186	97.0	26.0	462	504	456	418	93.6	26.1	495	501	455	449		
RT70	54.75	186	97.8	25.9	489	542	485	437	94.5	25.9	522	538	483	468		
PV70	54.75	186	96.9	25.8	483	526	469	431	93.6	25.9	516	522	468	462		
RT80	60.25	186	98.2	28.8	510	571	524	468	94.9	28.9	545	568	523	501		
PV80	60.25	186	97.5	28.8	505	556	509	462	94.1	28.8	539	552	507	495		

XIII. UNIT NUMBER DESCRIPTION

<i>Digit</i>	E	X	X	—	1	2	3	4	5	6	7	8	9	10	11	12	13	14	15	16	17	+
<i>Item</i>	Prefix				UT	CA	FT	FM	RA	CO	GT	GC	SV	MT	MS	AI	AC		AS			
	(Internal use Only)																					

1, 2 - Unit Type [UT]

RT - Natural Vent Rooftop
 PV - Power Vented Rooftop
 AH - Air Handler
 EV - Evaporative Cooler Only

3, 4 - Capacity [CA]

Single Furnace

10 - 100,000 BTU/HR
 15 - 150,000 BTU/HR
 20 - 200,000 BTU/HR
 25 - 250,000 BTU/HR
 30 - 300,000 BTU/HR
 35 - 350,000 BTU/HR
 40 - 400,000 BTU/HR

Double Furnace

50 - 500,000 BTU/HR
 60 - 600,000 BTU/HR
 70 - 700,000 BTU/HR
 80 - 800,000 BTU/HR

Triple Furnace

12 - 1,200,000 BTU/HR

5 - Furnace / Access Type [FT]

A - Standard Temperature Rise (20-60 Deg. F), Right Side Access
 B - Standard Temperature Rise (20-60 Deg. F), Left Side Access
 *C - High Temperature Rise (60-90 Deg. F), Right Side Access
 *D - High Temperature Rise (60-90 Deg. F), Left Side Access
 0 - None
 Z - Other

*Note: Unit Type [PV] not available in Capacity [30].

6 - Furnace Construction Material [FM]

1 - Aluminized Steel
 2 - 409 Stainless Steel (First Furnace Only)
 3 - 409 Stainless Steel (All Furnace Sections)
 4 - 321 Stainless Steel (First Furnace Only)
 5 - 321 Stainless Steel (All Furnace Sections)
 6 - 409 Stainless Steel Package (First Furnace Only)
 7 - 409 Stainless Steel Package (All Furnace Sections)
 8 - 321 Stainless Steel Package (First Furnace Only)
 9 - 321 Stainless Steel Package (All Furnace Sections)
 0 - None
 Z - Other

7 - Rooftop Arrangement (B - L assumes furnace sections) [RA]

A - Duct Furnace	M - Air Handler (Standard)
B - Blower (Standard)	N - Air Handler (Standard) / Plenum
C - Blower (Standard) / Plenum	P - Air Handler (Standard) / Evap.
D - Blower (Standard) / Evap.	R - Air Handler (Standard) / Evap. / Plenum
E - Blower (Standard) / Evap. / Plenum	S - Air Handler (High CFM)
G - Blower (High CFM)	T - Air Handler (High CFM) / Plenum
J - Blower (High CFM) / Plenum	U - Air Handler (High CFM) / Cooling
K - Blower (High CFM) / Cooling	W - Air Handler (High CFM) / Cooling / Plenum
L - Blower (High CFM) / Cooling / Plenum	0 - None
	Z - Other

8 - Coil Options [CO]

A - DX Coil, 4 Row, Single Circuit	E - Chilled Water Coil, 4 Row
B - DX Coil, 4 Row, Dual Circuit	G - Chilled Water Coil, 6 Row
C - DX Coil, 6 Row, Single Circuit	0 - None
D - DX Coil, 6 Row, Dual Circuit	Z - Other (Special)

9 - Gas Type [GT]

1 - Natural Gas
 2 - LP Gas (Propane)
 3 - Natural Gas w/100% Shutoff
 0 - None

10 - Gas Control [GC]

A - Single Stage Gas (Standard)
 B - Two Stage Gas
 H - Electronic Modulation w/Room Sensing
 J - Electronic Modulation w/Duct Sensing
 K - Electronic Modulation w/Duct Sensing & Ovrd. Stat
 L - Electronic Modulation w/External 4-20 mA Input (Furnace One)
 M - Electronic Modulation w/External 4-20 mA Input (All Furnaces)
 N - Electronic Modulation w/External 0-10 VDC Input (Furnace One)
 P - Electronic Modulation w/External 0-10 VDC Input (All Furnaces)
 R - Two Stage Remote Temperature Control w/Duct Sensor
 S - Three Stage Remote Temperature Control w/Duct Sensor
 T - Four Stage Remote Temperature Control w/Duct Sensor
 U - S-350 2 Stage Modular Electronic Control System
 W - S-350 3 Stage Modular Electronic Control System
 X - S-350 4 Stage Modular Electronic Control System
 Y - S-350 6 Stage Modular Electronic Control System
 0 - None
 Z - Other

11 - Supply Voltage [SV]

1 - 115/1/60	5 - 230/3/60
2 - 208/1/60	6 - 460/3/60
3 - 230/1/60	7 - 575/3/60
4 - 208/3/60	0 - None
	Z - Other

12 - Motor Type [MT]

1 - Open Drip Proof (Standard)	4 - Premium Efficiency, Totally Enclosed
2 - Totally Enclosed	0 - None
3 - Premium Efficiency, Open Drip Proof	Z - Other

13 - Motor Sizes [MS]

A - 1/2 HP. w/Contactor	M - 1-1/2 HP. w/Mag. Starter	1 - 1 HP. VFD
B - 3/4 HP. w/Contactor	N - 2 HP. w/Mag. Starter	2 - 1-1/2 HP. VFD
C - 1 HP. w/Contactor	P - 3 HP. w/Mag. Starter	3 - 2 HP. VFD
D - 1-1/2 HP. w/Contactor	R - 5 HP. w/Mag. Starter	4 - 3 HP. VFD
E - 2 HP. w/Contactor	S - 7-1/2 HP. w/Mag. Starter	5 - 5 HP. VFD
G - 3 HP. w/Contactor	T - 10 HP. w/Mag. Starter	6 - 7-1/2 HP. VFD
H - 5 HP. w/Contactor	U - 15 HP. w/Mag. Starter	7 - 10 HP. VFD
J - 1/2 HP. w/Mag. Starter	0 - None	8 - 15 HP. VFD
K - 3/4 HP. w/Mag. Starter	Z - Other	
L - 1 HP. w/Mag. Starter		

14 - Air Inlet Configuration [AI]

1 - Outside Air (OA)	4 - Outside Air and Return Air (OA/RA)
2 - Outside Air w/Air Hood	5 - Outside and Return Air w/Air Hood
3 - Return Air (RA)	0 - None
	Z - Other

15 - Air Control & Damper Arrangement [AC]

A - Outside Air 2 Pos. Motor / Spring Return
 B - Return Air 2 Pos. Motor / Spring Return
 C - OA/RA 2 Pos. / Spring Return
 D - OA/RA Mod. Mtr. w/Mixed Air Control / Min. Pot.
 E - OA/RA Mod. Mtr. w/Mixed Air Control / Min. Pot. / SR
 G - OA/RA Mod. Mtr. w/Mixed Air Control
 H - OA/RA Mod. Mtr. w/Mixed Air Control / SR
 J - OA/RA Mod. Mtr. w/Min. Pot.
 K - OA/RA Mod. Mtr. w/Min. Pot. / SR
 L - OA/RA Mod. Mtr. w/Dry Bulb / Mixed Air Control / Min. Pot.
 M - OA/RA Mod. Mtr. w/Dry Bulb / Mixed Air Control / Min. Pot. /SR
 N - OA/RA Mod. Mtr. w/Enthalpy Controlled Economizer / SR
 P - OA/RA Mod. Mtr. w/Pressure Control (Space Pressure)
 Q - OA/RA Mod. Mtr. w/Carbon Dioxide (CO₂) R/A Monitor
 R - OA/RA Mod. Mtr. w/S-350-P Proportional Mixed Air Control / SR
 S - OA/RA Mod. Mtr. w/0-10 VDC & 4-20 mA Analog Input (External Input)
 T - OA/RA Mod. Mtr. w/0-10 VDC & 4-20 mA Analog Input / SR (External Input)
 U - ASHRAE Cycle I (OA/RA 2 Pos. Mtr. w/Warm-up Stat / SR)
 W - ASHRAE Cycle II (OA/RA Mod. Mtr. w/Warm-up Stat / Mixed Air / Min. Pot. / SR)
 X - ASHRAE Cycle III (OA/RA Mod. Mtr. w/Warm-up Stat / Mixed Air / SR)
 Y - Manual Dampers
 0 - None
 Z - Other

MOD = Modulating Damper Motor
OA = Outside Air RA = Return Air SR = Spring Return

16 - Accessories [AS]

A1 - Moisture Eliminators	H1 - Return Firestat	J1 - Interlock Relay - 24V Coil DPDT 10A, Plug-in
A2 - Horizontal Return	A2 - Supply Firestat	J3 - Interlock Relay - 24/115V Coil SPDT 10A
A3 - Low Leak Damper	H3 - Freezestat w/Time Delay	J4 - Interlock Relay - 24V Coil 4PDT 10A
A5 - Furnace Drip Pan, 409 Stainless	H4 - Ambient Lockout - Single Furnace	K1 - Manual Reset High Limit Switch
A6 - High Altitude Unit	H6 - Ambient Lockout - Dual Furnace	K2 - High / Low Gas Pressure Limit Switches
A7 - High Pressure Regulator	H7 - Ambient Lockout - Triple Furnace	K3 - Status Lamp (Elec. Cabinet)
A7-1/2-1 - Regulator for 0.5-10 PSI		K4 - Fan Time Delay (Arrangement "A" Only)
A7-3/8-1 - Regulator for 10-20 PSI		K5 - Air Flow Prove Switch (Dwyer 1910-0) †
A7-5/16-1 - Regulator for 20-35 PSI		
A8 - Unit De-rate		L1 - 30 Amp, Fused Disconnect Switch †
		L2 - 30 Amp, Non Fused Disconnect Switch †
B1 - Filters - 1" WA (Standard)		L3 - 60 Amp, Fused Disconnect Switch †
B2 - Filters - 2" WA		L4 - 60 Amp, Non Fused Disconnect Switch †
B3 - Filters - 2" TA		
B4 - Filters - 1" 30%		N2 - Through the Base Utility Penetration
B5 - Filters - 2" 30%		N3 - Service Convenience Package
		N6 - Double Wall Construction
C1 - Evap. Cooler - Fill & Drain Kit		N7 - Vent Cap Extension (Unit Type RT only)
C2 - Evap. Cooler - 12" CELdek® Media		N9 - ERMS Connections
C3 - Evap. Cooler - Freezestat w/o Time Delay		
C4 - Evap. Cooler - 8" GLASdek® Media		R1 - Field Installed VFD
C5 - Evap. Cooler - 12" GLASdek® Media		R2 - Factory Installed VFD
		R3 - VFD Remote Keypad for use with w/R1 †
D1 - Time Clock - 7 Day †		R4 - CO ₂ Sensor - 100% OA †
D2 - Time Clock - 24 Hour †		R5 - CO ₂ Sensor - Mixed Air †
D6 - Pre-Purge Delay, 60 s. (PV Only)		R6 - Pressure Sensor †
		R7 - 2-Speed VFD Relays
E1 - Clogged Filter Switch		R8 - 3-Speed VFD Relays
E2 - G.F.I. Convenience Outlet 115VAC †		R9 - VFD Enclosure for use with R2
E3 - Remote Control Panel †		
E4 - Manual Blower Switch		0 - None
		Z - Other (Specify)
F1 - Ductstat - One Stage †		
F2 - Ductstat - Two Stage †		
G1 - Thermostat - T87K w/Subbase †		
G2 - Thermostat - T87K w/Subbase & Guard †		
G3 - Thermostat - T834N w/Subbase (Sterling Stat) †		
G4 - Thermostat - TH8320R - 7 Day Programmable †		
G5 - Thermostat - TH5220D (Two Stage) †		
G6 - Locking Thermostat Cover †		

Note: All thermostats are mercury free.

† = Field Installed

ENGINEERED PRODUCTS ROOFTOP ARRANGEMENTS (RA)*

NATURAL VENT	(RA)	POWER VENT	AIR HANDLERS	(RA)
	A			M
	B			N
	C			P
	D			R
	E			S
	G			T
	J			U
	K			W
	L			

***Notes:** 1. Arrangements are shown with the maximum number of furnaces available.
2. Optional air inlet hood shown in dotted lines.

Legend: B/F/D = Standard Blower/Filter/Damper, SP = Supply Plenum, EV = Evaporative Cooler, F/D = Filter/Damper, B = High CFM Blower, CC = Cooling Coil

Capacity: (CA) 10/40 = 1 furnace
(CA) 50/80 = 2 furnaces
(CA) 12 = 3 furnaces

